



Gascard NG

INFRARED GAS SENSOR

USERS MANUAL

Issue 1.02 July 2014

A DIVISION OF EDINBURGH INSTRUMENTS

Warning!

The Gascard NG is not suitable for the detection of flammable gases or mixtures of gases that are flammable or will become flammable if mixed with Air. If the device that will contain the Gascard NG is to be used with flammable Gases or flammable gas mixtures appropriate safeguards must be put in place to make the device suitable for such use including but not limited to, flame proof housing, flame arrestors and appropriate certification (ATEX or equivalent) for the intended use.

The Gascard NG is NOT hermetically sealed and will leak small quantities of the sample gas in to its surroundings. Gases such as Carbon monoxide are extremely **TOXIC and so potentially harmful levels may build up inside enclosures and suitable measures such as forced ventilation to a safe area need be taken to avoid this risk. Similarly potentially explosive levels of Methane or other flammable sample gases may build up inside enclosures and appropriate precautions should be taken when working on equipment of this type.**

© Edinburgh Instruments Limited, 2008, 2012, 2014

All rights reserved. No part of this document may be reproduced or transmitted in any form or by any means without prior permission of the copyright holder.

The product described in this manual is subject to continuous development and, while every effort has been taken to ensure that the information given is correct, Edinburgh Instruments Limited cannot accept any liabilities for errors and omissions or their consequences.

Contents

1.	INTRODUCTION	1
	PRINCIPLE OF OPERATION	2
2.	MECHANICAL INSTALLATION	3
3.	PARTS IDENTIFICATION	4
	3.1. Front view	4
	3.2. Back View	5
4.	BIT SWITCH SETTINGS	6
5.	ELECTRICAL REQUIREMENTS	7
	5.1. Power In	7
	5.2. Signal-Out	8
	5.3. Output Resolution	9
6.	TEMPERATURE AND PRESSURE CORRECTION	10
	6.1. Temperature Correction	10
	6.2. Pressure Correction	11
7.	DIGITAL RESOLUTION	12
8.	GAS REQUIREMENTS	13
	8.1. Pump Aspiration	13
	8.2. Gas Flow Rates	14
	8.3. Diffusion Aspiration (Not Currently Available)	14
9.	SAFETY NOTE	15
10.	CALIBRATION	15
	10.1. Calibration Checking/Adjusting Procedure	16
	10.2. Pressure Effects (a reminder)	17
	10.3. Calibration Accuracy	17
11.	FILTERING	17
12.	LED'S, FAULTS AND ERROR INDICATIONS.	17
13.	SPECIFICATION	19
14.	WARRANTY	21
15.	EXPANSION FACILITIES	22
	15.1. Serial Communications Port	22
	15.2. Expansion Facility and Application Notes	22
16.	PHYSIOLOGICAL EFFECTS OF CARBON DIOXIDE	22
17.	AMENDMENTS AND COMPARISON WITH GASCARD II	23
18.	DOCUMENT CHANGE HISTORY	24

This page is deliberately left blank

1. Introduction

Please take a few minutes to read this manual to ensure ease of installation with other equipment and to maximise the use of the facilities available.

The Gascard NG infrared gas sensor is designed for ease of integration with a wide range of systems requiring accurate and reliable measurement of carbon dioxide, carbon monoxide or methane gas concentrations in a background that is Air or Air like. (Other background gases are available upon request).

The sole use of the Gascard NG is the detection of the specified gas in the specified background over the specified range and within the specified conditions and for no other purpose.

The sensor head is based on a patented technique that provides true, dual wavelength infrared sensing with no moving parts. The result is a low drift, high accuracy sensor with a fast response time and low power consumption.

The Gascard NG replaces the Gascard II and is in most respects backward compatible with it. The main new features of the Gascard NG are:-

- Completely new electronics which take advantage of the greatly increased power and versatility of modern Microprocessors
- Onboard Barometric Pressure Correction in the range 800 mbar to 1150 mbar
- More extensive temperature compensation which almost eliminates the zero and span temperature coefficients.
- Lower operating voltage (7V) and wider operating voltage range (7V to 30V).
- True RS232 communications for control and data logging.
- Optional onboard LAN support
- Future expansion facilities to allow the addition of more gas detection channels for both NDIR and Chemical sensors.

Each Gascard NG is supplied fully tested and calibrated, with a 2-year warranty against defective workmanship and parts.

Principle of Operation

Many gases including CO₂, CO and CH₄ absorb energy in the infrared part of the spectrum. This absorption is selective, occurring at specific frequencies corresponding to the resonant frequencies of bond vibrations within the molecule. Measuring at a characteristic absorption wavelength enables the detection of the gas and the strength of the absorption gives a measure of the gas concentration. The Gascard NG sensor optics comprise a robust infrared source, a gas sampling cell, two infrared filters and a matched twin element detector.

The infrared source is the hot filament of a tungsten lamp emitting a broad band of radiation that is then guided through the gas in the sample cell. The radiation then passes through either of the two filters. The two filters are selected so that one is coincident with the gas to be measured and the other is independent of any gas likely to be present in the cell. In the absence of gas (i.e. CO₂ or CO or CH₄) the energy reaching the two detectors is equal and at a maximum and as the sample gas concentration increases the amount of infrared radiation reaching the two detectors differs due to absorption at one filter wavelength only. Electronic signal ratioing using a dedicated on board microprocessor gives the gas concentration, automatically compensated for source intensity changes or contamination of the optical elements. On board Pressure and Temperature sensors are used to compensate for Barometric Pressure and Environmental Temperature in order to give the indicated gas concentration as volume percent over a wide range of environmental conditions. The powerful microprocessor at the heart of the electronics offers many future expansion facilities.

2. Mechanical Installation

The sensor head and electronics are mounted on a standard Eurocard (dimensions 160 x 100mm) for ease of integration.

A 3 mm wide clearance area is available at the top and a 2mm wide clearance area is available at the bottom of the card for rail mounting.

Four 4.5 mm diameter mounting holes with a clear area of 6mm diameter are provided in the positions shown below.

Two 2.7 mm diameter holes are positioned at the front of the board (shown below) are provided for jacking handles or front panel mounting.

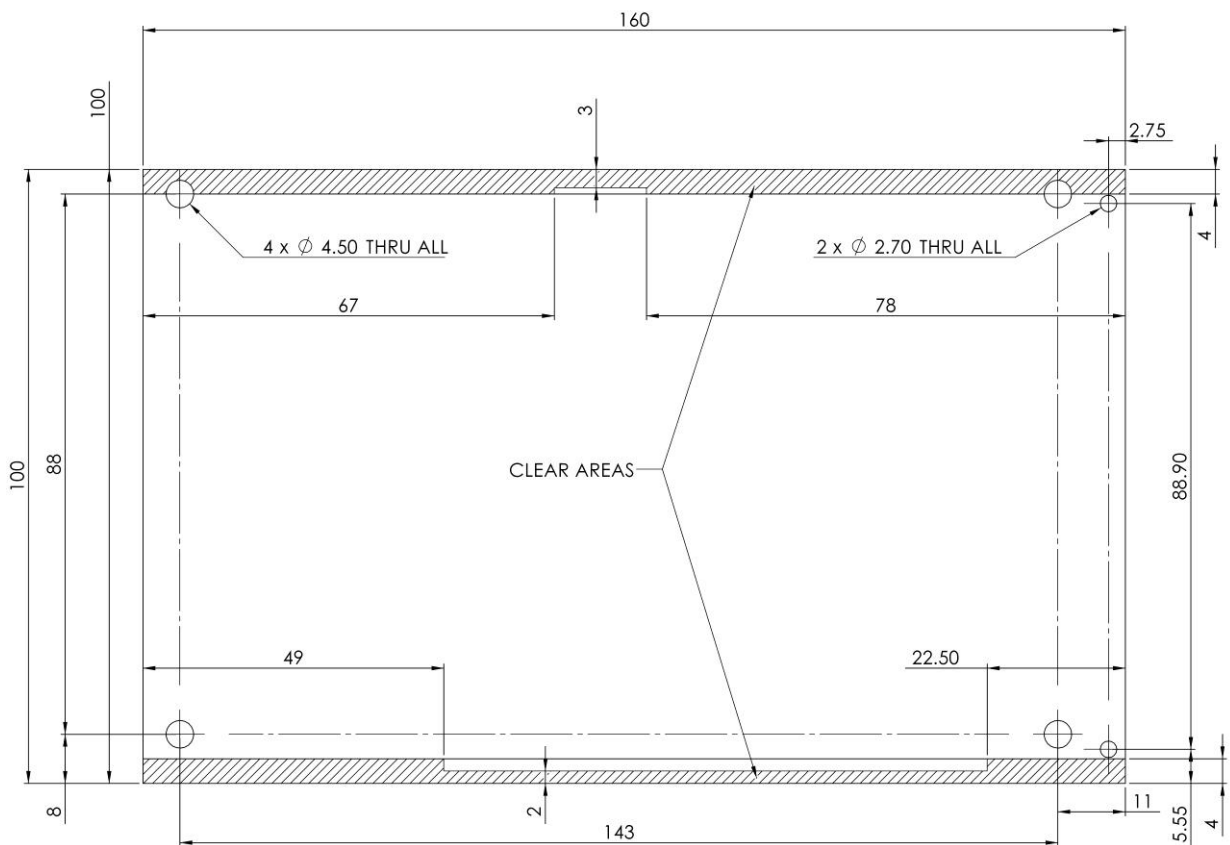
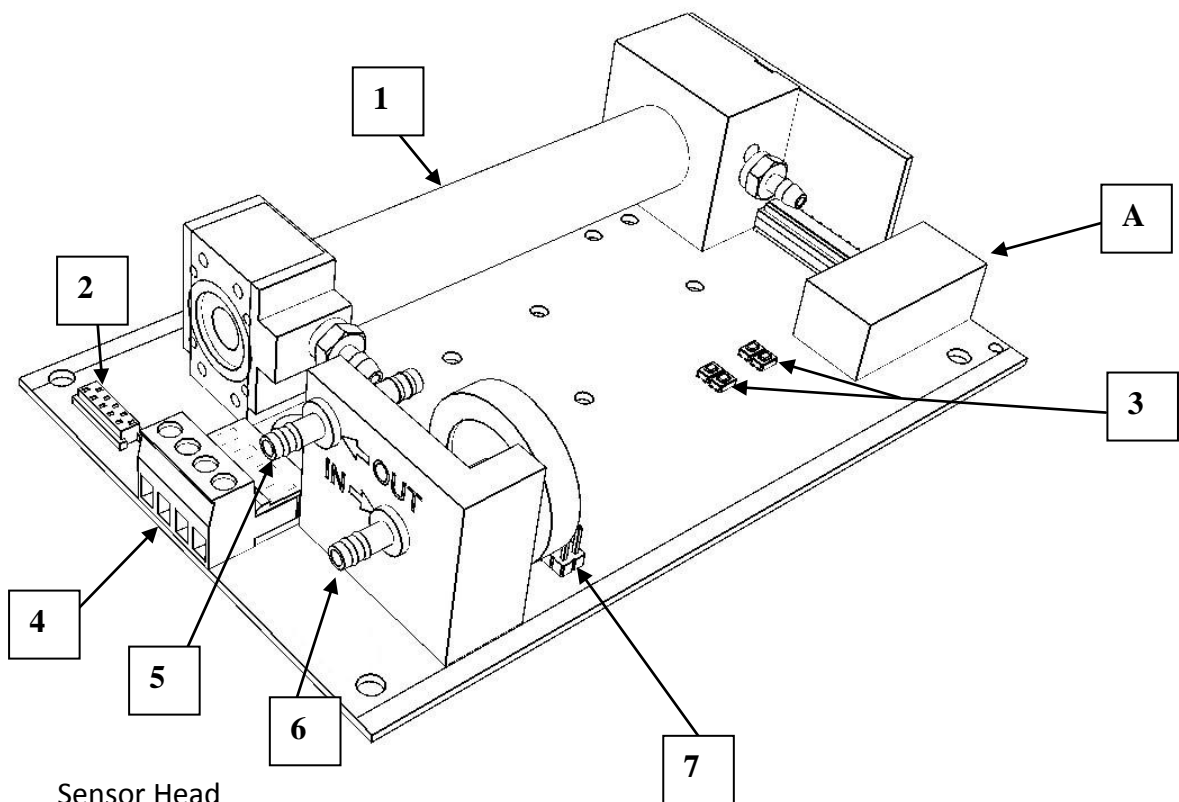

Figure 1 PCB Outline and Mounting Hole Drawing

3. Parts identification

Note: Some of the components on the pictures you will see may not be fitted on your physical board, or may be different, depending on the features you have. But the numbered components are available on all versions of the board. For clarity the pipe work is not shown.

3.1. Front view



1. Sensor Head
2. RS232 port
3. Zero and Span adjust push buttons
4. Power in & Analogue output (current) **J5**
5. Gas outlet
6. Gas inlet
7. Analogue output selector **J10** (issue D PCB only)
- A Ethernet port (Optional)

Figure 2 Front View of Gascard NG

3.2. Back View

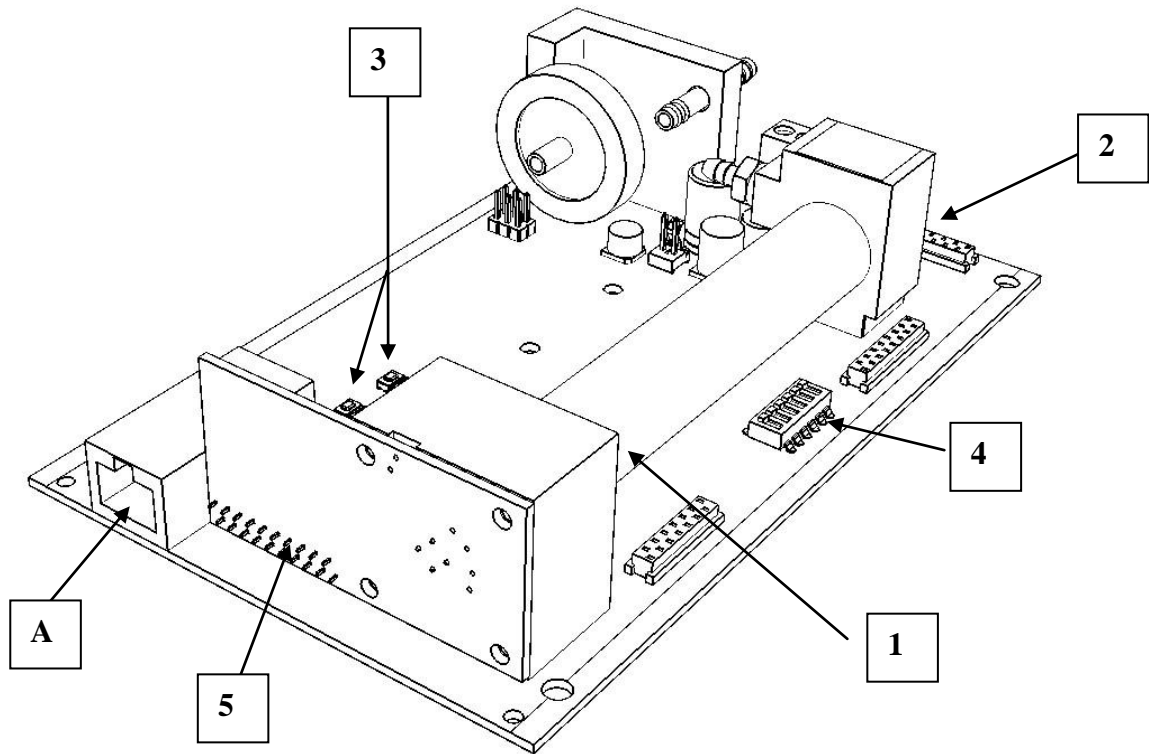

- 1. Sensor Head
- 2. RS232 port
- 3. Zero and Span adjust push buttons
- 4. Bit Switch
- 5. Pre-amp connection
- A Ethernet port (optional)

Figure 3 Back View of Gascard NG

4. Bit Switch Settings

The Gascard NG has a number of bit switches which enable the user to control various aspects of the sensor's behaviour. Bit switch 6 (see item 4 on Figure 3 and Figure 4) is used to change the output filtering between the standard adaptive type filter and a simple RC Filter. The value of the RC filter is factory set to 8 seconds by default but this may be altered by the user through the RS232 port (see RS232 port user manual).

Bit switch 5 sets the current loop output mode to be either 4-20mA or 0-20mA.

In the Gascard NG switches 1 to 4 have no function and must be left in the off position.

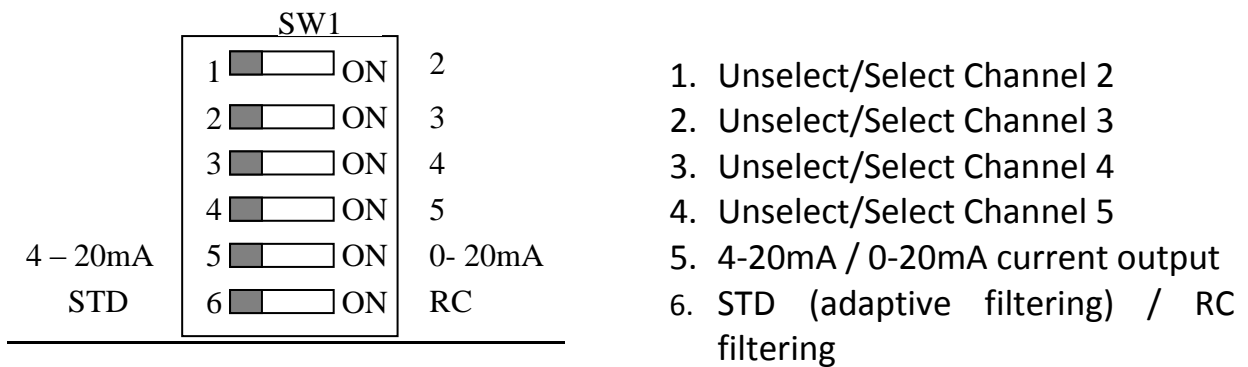

Figure 4 Bit switch Settings (item 4 on **Figure 3**)

5. Electrical Requirements

5.1. Power In

The Gascard NG requires a supply voltage (V_s) of +24V dc (+7 to +30V), fused 1500mA ANTISURGE supply, connected between pins 1 (V_s) and 2 (0V) the orange terminal block J5 shown as numbered item 4 in Figure 2 (the legend is revealed by removing the terminal plug). The power supply should maintain the voltage between 7V and 30V dc for all load conditions (see below) and all mains voltages. The Gascard NG has an on board 1500mA anti-surge resettable fuse for added protection.

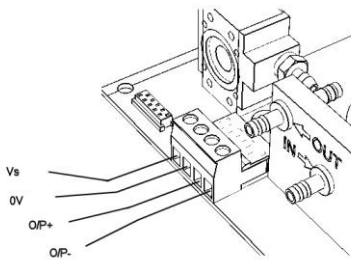

Figure 5 Power Input Connections

The load current taken by the sensor is not constant and in particular contains significant components at the source modulation frequency (8Hz for the Gascard NG). The average power required during normal operation is $\sim 4W$ (e.g. 350mA at 12V) at room temperature but this increases for colder environments.

The in-rush current at start up may have peaks up to 30A and an average of up to 2A for the first 40ms and the power supply should be capable of supplying this although the supply voltage need not be maintained during this time. The peak current then falls to that needed to supply 7W (e.g. 700mA at 10V) for a few minutes until the sensor thermostat has reached its operating temperature. The average power consumption during this period is 6W.

On powering up the Gascard NG unit, the system enters a software upload, self-test and warm-up period of 30 seconds duration during which the current output is indeterminate. Once the 30 seconds have elapsed, the output signal is proportional to the measured gas concentration. Any fault within the Gascard NG will then be indicated by the signal returning to either 0mA for the 4-20mA option or $>24mA$ if 0-20mA is selected.

5.2. Signal-Out

The analogue output (current) is available at the terminals marked O/P+ and O/P- on the terminal block J5 (see figure 2). The O/P- terminal is connected to the 0V terminal thereby referencing the analogue output to the negative power rail.

The instrument is supplied with a 4-20mA linear analogue output as standard. If a 0-20mA output is required then the bit-switches (item 4 on Figure 3) labelled 4-20mA/0-20mA should be switched over the right side (see silkscreen).

The maximum load that may be driven at 20mA is dependent on the supply voltage and may be calculated from the diagram below:-

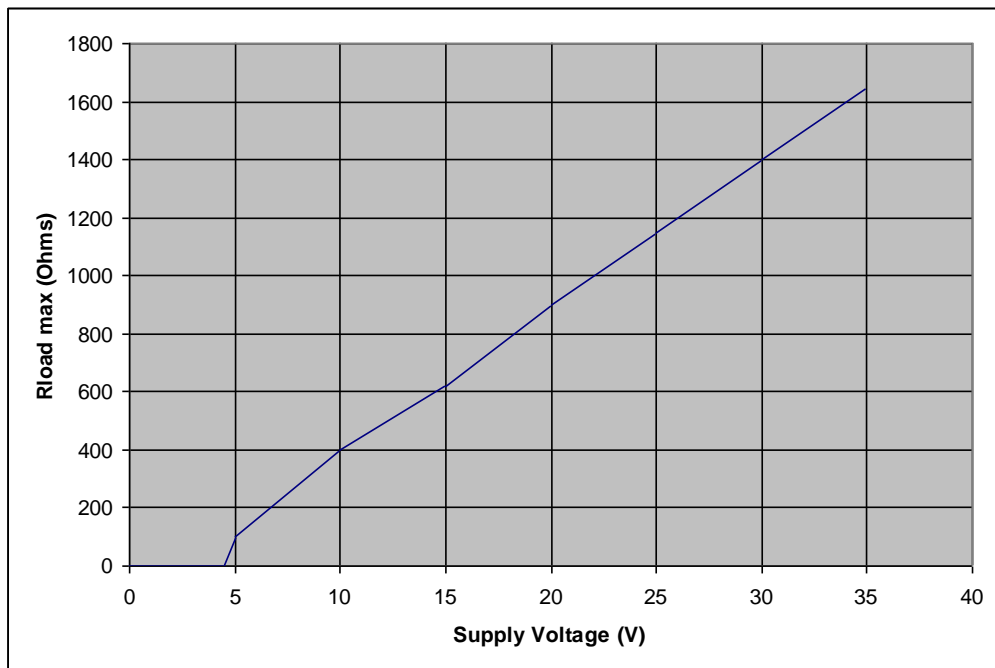

Figure 6 Maximum load Resistance vs. supply voltage

On Issue D Main PCB's, before using the current output, ensure that the analogue output selector (Item 7 on **Figure 2**) has been linked as in **Figure 7** Below:



Figure 7 J10 Jumper settings for Current output

Issue F boards do not have jumpers and the output from J5 is always current.
The output may be checked by connecting a DMM (in current mode) directly to the J5 Terminals 3, O/P+ and 4, O/P- (COM) as shown below:

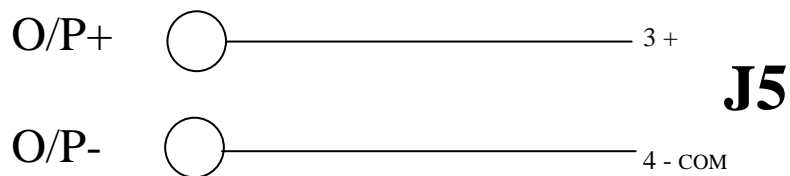

Figure 8 Output Current Test Configuration

Optionally a voltage output is available from Output 1 on the lower edge of the main PCB between the terminals labelled Gnd and Vout. (Minimum load resistance 10M)

5.3. Output Resolution

The Gascard NG is fitted with a 15 bit digital to analogue converter (DAC). This gives an output resolution (steps) of 0.0006mA.

6. Temperature and Pressure Correction

Gases are compressible and this means that there are various ways of expressing the gas concentration (volume percent, partial pressure, and density). Infrared instruments operate by measuring the amount of infrared energy absorbed by the sample of gas; they therefore fundamentally measure mole density (the number of molecules in the path of the beam).

6.1. Temperature Correction

In most applications, the ambient temperature will vary causing a proportional variation in the molecular density of the gas. As the Gascard NG is an NDIR instrument it measures mole density, the relationship between mole density and volume percent is given by the ideal gas law $\frac{P_1V_1}{T_1} = \frac{P_2V_2}{T_2}$ so for constant pressure the mole density is proportional

to $\frac{T_1}{T_2}$ which at room temperature gives a variation of ~0.3% of concentration reading per °C.

There is also an instrumentation factor that contributes a variation that is dependent on the construction of the optical system and gives both a variation at zero concentration and a variation proportional to concentration.

The optical sensor head in the Gascard NG is equipped with a temperature sensor and the measured temperature is used by the microprocessor to automatically compensate the output for both types of variation with temperature so that the indicated concentration is in True % V/V and independent of temperature in the range 0 to 45°C.

6.2. Pressure Correction

As with changes in temperature, changes in pressure will change the molecular density of the gas. Again, as the Gascard NG measures mole density and the relationship between mole density and volume percent is given by the ideal gas law $\frac{P_1V_1}{T_1} = \frac{P_2V_2}{T_2}$. So

at constant temperature $T_1 = T_2$ the mole density is proportional to $\frac{P_2}{P_1}$ or $\sim 0.1\%$ per mbar.

For small molecules there is also an increase in observed absorption per molecule with pressure due to line broadening effects. The sum of these two effects is, for small molecules such as CO_2 and CH_4 , that the True % V/V is related to the value measured internally by an uncorrected Gascard by the approximate relationship.

$$\text{True \% V/V} = \text{Indicated Value} \times \left\{ \frac{P_0}{1.5 \times P - 0.5 \times P_0} \right\}$$

where P = ambient pressure(mBar)

$$P_0 = 1013.25 \text{ (mBar)}$$

However, the Gascard NG is equipped with a Barometric pressure sensor and the measured pressure is used by the microprocessor to automatically compensate the output for variations with pressure so that the indicated concentration is in True % V/V and almost independent of pressure variation in the range 800 to 1150 mb.

7. Digital Resolution

The Gascard NG can be fitted with a 4-digit LCD display which may be bought as an accessory from Edinburgh Instruments.

The display resolution is determined by the measurement range of the Gascard NG and is given in Table 1 below.

Measurement Range	Resolution
2000ppm	1ppm
3000ppm	1ppm
5000ppm	1ppm
1%	10ppm
3%	10ppm
10%	0.01%
30%	0.01%
100%	0.1%

Table 1 Display Resolution

8. Gas Requirements

It is the customer's responsibility to ensure that the gas supplied to the Gascard NG is clean and free from particulate matter. Even in relatively clean "office" environments, the air will contain significant amounts of particulate matters that should be removed by external filtering. It should also be noted that although the Gascard NG's measurement system is insensitive to water vapour, the relative humidity must remain below that required for condensation to occur.

The Gascard NG is fitted with an internal hydrophobic particle filter, which will protect the sensor head against the ingress of water and particulate matter. However, in the event that the equipment is operated without adequate filtration, this internal filter may become blocked and require replacement.

Care should be taken to ensure that the gas supply pipes are connected in accordance with the input/output directions to ensure that the internal filter is utilised.

Replacement filter capsules are available from Edinburgh Instruments sales.

<p style="text-align: center;">IMPORTANT</p> <p style="text-align: center;">DO NOT OPERATE THE GASCARD WITHOUT A FILTER</p>

8.1. Pump Aspiration

Edinburgh Instruments recommend that an oil free pump should be used to aspirate the sensor head.

8.2. Gas Flow Rates

The Gascard NG calibration is insensitive to the actual flow rate used so long as it falls within the range 0.2 litres per minute to 1.2 litres per minute. The minimum usable flow rate is determined by the response time of the unit and should not be less than 0.2 litres per minute. The maximum flow rate is determined by the consideration that very high flow rates will cause a pressure increase and turbulence in the sensor head, which may lead to incorrect pressure measurement and inaccurate indication.

The Gascard NG is calibrated at the prevailing room temperature and pressure within our factory at the time of calibration and with a flow rate of 1 litre per minute.

If the flow rate is higher than 1 litre per minute or there is any restriction or blockage of the gas exhaust an error in the indicated pressure may be caused leading to inaccurate readings especially if the internal pressure exceeds the range of the pressure sensor. Care should therefore be taken not to restrict the exhaust flow or use excessively high or low flow rates.

8.3. Diffusion Aspiration (Not Currently Available)

9. Safety Note

Where the Gascard NG is to be used in carbon dioxide monitoring applications it should be noted that since CO₂ is heavier than air, the gas inlet pipe should be positioned at the lowest point in a system, to ensure accurate gas sampling.

10. Calibration

The Gascard NG dual wavelength sensor is inherently stable and will maintain its calibration over extended periods with minimal maintenance. We recommend that the calibration is checked every 12 months. Any adjustment required should be small.

ZERO (nitrogen) and SPAN calibration gases must be applied to the sensor in order to check its calibration. To supply gas from a pressurised bottle, a pressure regulator, a needle valve, a gas flow meter and an inlet pipe are required. When supplying gas, the following conditions should be maintained:-

- ◆ the CO₂, CH₄, or CO concentration of the SPAN gas should be between 80% and 100% of the instrument full scale range.
- ◆ the tolerance (accuracy) of the SPAN gas volume concentration of the gas bottle should be $\pm 2\%$ or better.
- ◆ output pressure from the regulator should only slightly exceed the ambient pressure
- ◆ the nominal gas flow should be about 1.0 l/min
- ◆ The “out” port of the sensor should not be restricted

The material of the gas inlet pipe can be nylon, PVC or neoprene; never use silicone rubber as this can affect the gas concentration. The inlet pipe should not be longer than 2 metres.

CAUTION

Never connect unregulated cylinders or other high pressure sources to the sensor as the high flow rate from the cylinder may damage the instrument.

10.1. Calibration Checking/Adjusting Procedure

The procedure for checking/adjusting the calibration is as follows:-

1. The Gascard NG should be powered for 30 minutes before checking its calibration.
2. Attach the ZERO gas source to the gas inlet. Adjust the needle valve to provide approx. 1l/min to the instrument and allow to flush for about 30 seconds before checking the reading. If the reading is outside the required specification, use the ZERO adjust buttons on the main PCB to increase or decrease the indication as necessary.

3. Repeat step 2 above with SPAN gas and use the SPAN adjust buttons on the main PCB to increase or decrease the indication until it is the same as the bottle concentration.

There is no need to correct the bottle concentration for pressure or temperature, since the Gascard NG is fully compensated for these factors.

NOTE - Always make adjustments with ZERO gas first and then with SPAN gas.

10.2. Pressure Effects (a reminder)

If the exhaust line from the Gascard NG vents directly to the atmosphere, then barometric pressure will control the internal pressure of the gas sample cell and hence the number of infrared absorbing molecules in the optical path. The internal pressure sensor will compensate for barometric changes but only if the pressure in the head is in the range 800 to 1150 mbar. Outside this range the pressure cannot be correctly measured and the indicated concentration will be incorrect. For this reason the Gascard NG should not be operated out with this pressure range.

10.3. Calibration Accuracy

The accuracy of the calibration will depend on the accuracy of the gas composition used. Calibration gas is available in a range of specified accuracy and the user should ensure that the accuracy of gas used is appropriate to the application requirements.

11. Filtering

The Gascard NG provides a standard optimised response time (T_{90}) of 10 seconds with the bit-switch 6 (see Figure 4) on position "STD". Alternatively an RC type response can be selected by setting bit-switch 6 to position "RC". The time constant of the RC filter is programmed using an internal variable and may be set and viewed using the RS232 port and terminal software (see Procedures for RS232 communication with the Gascard NG). Smaller time constants produce more rapid response but reduced short term stability (i.e. a noisier output).

12. LED's, Faults and Error Indications.

The Gascard NG has self monitoring routines that check for faults within the system and report these using LED's on the main PCB and on the display if one is fitted.

The main functions of the 6 LED's on the Gascard NG main PCB are described in Table 2 and Table 3 and lists the detectable errors and describes the way in which they are indicated to the user by the LED's.

LED No	Colour	Function	Description	Normal Condition
1	Orange	Lamp Fault (If ON or Flashing)	LAMP FAULT	OFF
2	Red	Detector Fault (If ON or Flashing)	DET. FAULT	OFF
3	Green	Transmitting Data (If Flashing)	TX	Flashing
4	White	Receiving Data (If Flashing)	RX	OFF
5	Yellow	Calibration Running (If ON)	CAL	Flashing
6	Blue	Power Indicator (Powered if ON)	PWR	ON

Table 2 LED Colours and Function

Error #	Description	LED Indication
1	Lamp fault	LED1 (Orange) & LED2 (Red) both on
2	Concentration < -5% Range	(Output under range) No LED indication
3	Concentration > 130% Range	(Output over range) No LED indication
4	DSP temperature > 70C	LED2 (Red) flashing slowly (about 2s period)
5	DSP temperature < 0C	LED2 (Red) flashing slowly (about 2s period)
6	Head temperature > 70C	LED2 (Red) flashing fast (about 1s period)
7	Head temperature < 0C	LED2 (Red) flashing fast (about 1s period)
8	Reference signal Low (< 50%)	LED1 (Orange) & LED2 (Red) flashing alternately
9	Sample Signal Low (<10%)	LED1 (Orange) & LED2 (Red) flashing alternately

Table 3 Error Number and LED Indication

On the 4 digit LCD errors are reported as “Err.” alternating with “F. XXX” where XXX is the fault number.

13. Specification

Measuring Range: ⁴	CO₂	CH₄ ¹	CO ²
	0-2000ppm	0-10%	0-100%
	To	To	
	0-100%	0-100%	
Accuracy:	$\pm 2\%$ of range ³ $\pm < 0.015\%$ of range per mbar		
Zero Stability :	$\pm 2\%$ of range (over 12 months) ³		
Repeatability:			
at zero	$\pm 0.3\%$ ³		
at span	$\pm 1.5\%$ ³		
Response Time:	bit switch selectable T ₉₀ = 10s or programmable RC		
Operating Temperature:	0-45°C		
Operating Pressure:	800-1150 mbar		
Zero Drift at Constant Temp.	$\pm 2\%$ per year ³		
Zero Drift due to Ambient Temp.	$\pm 0.03\%$ of range per °C (Standard Head)		
	$\pm 0.1\%$ of range per °C (Plus Head)		
Warm-up Time:			
Operational	1 min		
Full Specification	30 mins		
Humidity:	measurement unaffected by 0-99% RH, non-condensing		
Output:	linear 4-20mA, 0-20mA (bit switch selectable) maximum load dependent on supply voltage (see Figure 6)		
Controls:	zero and span adjust buttons		

Note:

- 1 Methane is flammable above ~4.5% in Air and Methane/Nitrogen mixtures above 14.3% will form flammable mixtures with Air which require special precautions to be taken to prevent explosion. If in doubt consult the appropriate MSDS for Methane or Methane mixtures.
- 2 CO is flammable above ~12.5% in Air and is extremely toxic see MSDS for Carbon Monoxide.
- 3 At 1013mbar, 25C and excluding calibration gas tolerance.
- 4 Other gases and ranges available with reduced specification.

Power Consumption:	6W (max) (supply voltage dependent)
Input Voltage Requirement:	24V dc (7-30V)
Weight:	0.3kg
Dimensions:	160x100x40mm
Expansion Facilities:	Display: LCD Remote zero and span buttons RS232 Ethernet (optional)
Parameters Under Bitswitch Control:	analogue output: 4-20mA or 0-20mA Response time/type: Adaptive filter or RC filter (programmable time constant)

14. Warranty

Edinburgh Instruments Ltd. guarantees the equipment against defective materials or workmanship for a period of two years from the date of the delivery. In no event shall the Company be liable for any consequential loss or damage arising from failure of the equipment under warranty.

At the end of the two-year period, all claims upon and all liability from failure of the equipment shall be absolutely at an end.

No warranty is made or implied as to the suitability of any equipment for the Purchaser's intended use beyond such performance specifications.

The Purchaser warrants

That they will carefully examine and list all parts of the equipment supplied by Edinburgh Instruments Ltd. and notify Edinburgh Instruments Ltd. in writing of any shortage, defect or failure to comply with the contract, which is or ought to be apparent upon such examination and test, within 48 hours of the equipment being delivered to or collected by the Purchaser.

That the equipment will be operated in accordance with the instructions and advice detailed in the appropriate operating instruction manual, or any other instructions that may be provided by Edinburgh Instruments Ltd. Edinburgh Instruments Ltd. shall not be held responsible for any defect arising from the Purchaser's failure to comply with these recommendations and instructions or from damage arising from negligence or exposure to adverse environmental conditions.

The warranty is effective only if:-

The equipment has been paid for in accordance with the normal payment terms.

Any defects in the equipment supplied are notified immediately by the Purchaser to Edinburgh Instruments Ltd.

The equipment is returned to Edinburgh Instruments Ltd. at its Livingston premises, transportation and insurance prepaid, and undamaged by the failure to provide sufficient packaging.

The warranty covers:-

Engineer costs to inspect and repair.

Materials or components, which require to be replaced.

Return carriage costs to the Purchaser.

The timing of the inspection and repair of the equipment will be determined entirely at the discretion of Edinburgh Instruments Ltd.

15. EXPANSION FACILITIES

15.1. Serial Communications Port

The serial communications (RS232) port offers access to the information stored in the microprocessor's memory and allows some internal parameters to be modified.

15.2. Expansion Facility and Application Notes

The following application notes are available on request from Edinburgh Instruments sales:-

- Serial communications port user manual.
- Local Area Network port user manual

16. PHYSIOLOGICAL EFFECTS OF CARBON DIOXIDE

%	EFFECT
0.03	None. Normal atmospheric concentration.
0.50	Slightly deeper breathing.
2.00	Lung ventilation increased by 50%.
3.00	Lung ventilation doubled.
5.0 - 10.0	Three-fold increase in respiratory rate leading to rapid exhaustion and headache.
Above 10.0	Intolerable panting, severe headache, collapse, followed by death.

17.Amendments and Comparison with Gascard II

Gascard II and Gascard NG are optically identical. The Gascard NG has a modernised and improved main PCB, giving on board pressure correction, full temperature correction, true RS232 communications, optional LAN/TCP/IP connectivity and greater all round flexibility. The new main PCB has built in features for future expansion for multi gas and multi sensor operation.

The display used on the Gascard NG is the same as that used on the GascardII unit but has different connections and so a patch cable is required to connect an old Gascard display to the Gascard NG.

18.DOCUMENT CHANGE HISTORY

Version	E.C.N	Date
1.00	First Issue	Jan 09
1.01	7107	Jan 12
1.02	7297	July 14