

GASCHECK CARBON DIOXIDE SENSOR

Operating Manual

Edinburgh Instruments Limited
2 Bain Square, Kirkton Campus
Livingston EH54 7DQ
UK
 44 (0)1506-425300
Fax 44 (0)1506-425320

© Edinburgh Instruments Limited, 2006

All rights reserved. No part of this document may be reproduced or transmitted in any form or by any means without prior permission of the copyright holder.

The product described in this manual is subject to continuous development and, while every effort has been taken to ensure that the information given is correct, Edinburgh Instruments Limited cannot accept any liabilities for errors and omissions or their consequences.

Contents

1. INTRODUCTION	2
2. PRINCIPLE OF OPERATION	2
3. INSTALLATION	3
3.1 A Mechanical installation - Basic GasCheck.....	3
3.2 Aspiration	4
3.2.1 Pumped aspiration	4
3.3 Electrical connection for GasCheck.....	5
3.5 Power supply requirements for GasCheck	7
4. USING THE OUTPUT.....	9
4.1 A Linearisation of the GasCheck	9
4.2 Temperature and Pressure correction	11
5. SERVICE AND MAINTENANCE	12
5.1 Calibration	12
5.2 Trouble shooting.....	15
5.3 Source replacement	15
6. TECHNICAL DATA	16
7. WARRANTY.....	18
8. DOCUMENT HISTORY CHANGE	19

1. INTRODUCTION

The GasCheck range of sensors employs high reliability infrared absorption technology to detect carbon dioxide. By using a physical measurement technique, the sensors offer high selectivity, fast response and are virtually immune to poisoning. By careful design of the electronics and optics, the GasCheck technology provides a stable sensor capable of accurate and reliable measurement without the need for frequent recalibration. The result is a device with both low initial cost and low cost of ownership.

The GasCheck range is designed to meet the needs of OEMs who require to monitor CO₂, but do not themselves have expertise in the specialist field of infrared technology. The sensors comprise the heart of an infrared detection system, offering the user a conditioned 0 - 1 V output for ease of installation. Surface mount electronics technology enables the GasCheck range to provide a complete infrared sensor sub-system in a compact format.

The main features of the GasCheck sensor are:

- high accuracy
- good long term stability
- low temperature coefficient
- conditioned voltage output
- negligible cross sensitivity
- low power
- fast response
- small size
- low mass

The GasCheck range comprises of three models.

1. **Basic GasCheck:-** ranges 3000ppm, 3% or 10% with a 0-1V non-linear output.
2. **GasCheck with linearisation:-** ranges 3000ppm, 3% or 10% with a 4 to 20 mA linear output.
3. **GasCheck with self referencing:-** ranges 3% or 10% with a 0 to 1V non linear output. This model is available with either the standard aspirated style or diffusion style sensor.

2. PRINCIPLE OF OPERATION

Many gases, including CO₂, absorb energy in the infrared band. This absorption is selective and occurs at specific frequencies corresponding to the resonant frequencies of bond vibrations within the molecule. Measuring a characteristic absorption enables the gas to be detected and the strength of the absorption gives a measure of the gas concentration.

The GasCheck sensor optics consists of an infrared source, a sampling cell, an infrared filter and a detector. In addition, the sensor includes electronics to drive the source and to process the signals from the detector.

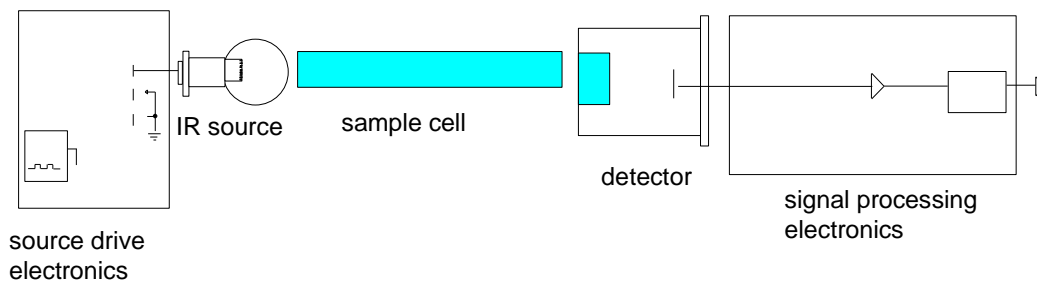

Figure 2.1 Schematic of the GasCheck sensor

The infrared source is the hot filament of a tungsten lamp emitting a broad band of radiation, which is then guided through the gas in the sample cell. The infrared then passes through a filter before reaching the detector. The filter selects a very narrow band of frequencies corresponding to a characteristic absorption band for CO₂. The amount of energy reaching the detector falls as the CO₂ concentration increases. Because the absorption of infrared by the gas is non-linear, the output signal is also non-linear.

3. INSTALLATION

3.1 A Mechanical installation - Basic GasCheck

The sensor is designed to be mounted directly onto a printed circuit board (PCB). The sensor should be secured with two M4 screws (M4 x 8 mm pan head screws with a plain and spring coil washer recommended). Pads should be provided on the PCB for electrical connection ($\varnothing 1.9$ mm pads with $\varnothing 1.0$ mm holes recommended) and the pins on the sensor should be soldered directly to these pads.

In designing the PCB to accept the sensor, consideration should be given to the inlet and outlet pipes to ensure that these do not collide with tall components.

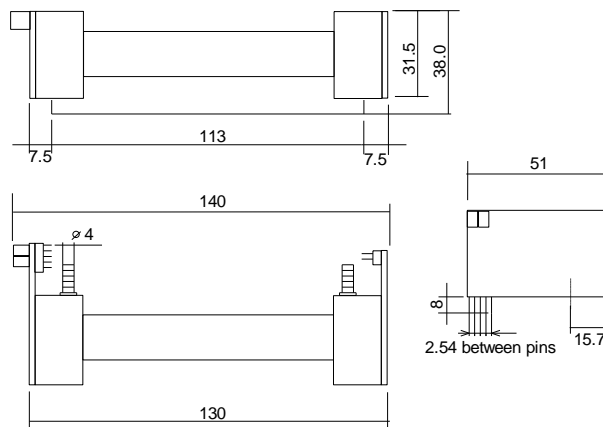

Figure 3.1 Dimensions (mm) of the GasCheck 3000ppm

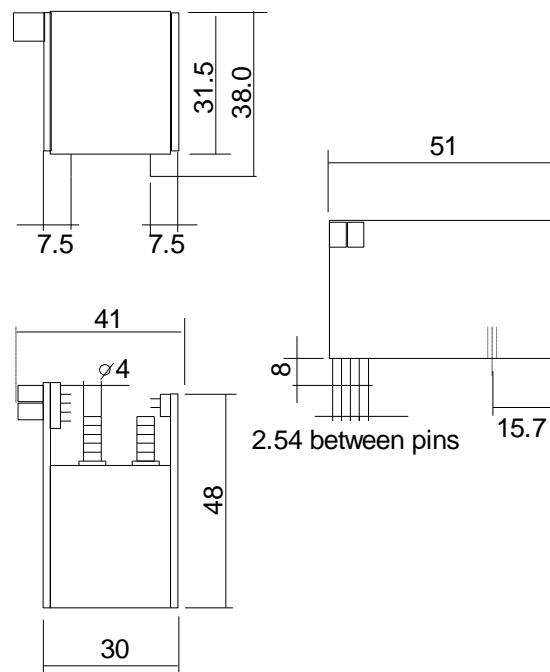

Figure 3.2 Dimensions (mm) for the GasCheck 3% and 10%

3.1 B Mechanical Installation - GasCheck with linearisation Board

Four mounting holes suitable for M4 screws are provided on a 45 x 140mm grid. If spacers are used, these should be at least 6mm high to provide adequate clearance for the surface-mount components on the underside of the PCB.

3.2 Aspiration

The sensors are available with two options for the aspiration of the cell:

- pumped aspiration
- diffusion aspiration through a permeable Vion strip (only available for the GasCheck with self-referencing option)

3.2.1 Pumped aspiration

With pump-aspirated sensors, a separate pump is required to flow gas into the sensor. The flow rate should be between 0.2 and 1.0 litres per minute. Lower flow rate will lead to slow response times; higher flow rates will cause the output to become unstable. In calculating the response time, consideration should be given to the dead volume within the complete system comprising both the sensor head and the pipework. The dead volumes for the various sensor heads are:

Range	Dead volume
3000 ppm	9 cm ³
3 %	4 cm ³
10 %	4 cm ³

Connection to the sensor is via the barbed gas ports on the side of the head. These are suitable for N3 (3 mm bore) soft flexible tubing. Neoprene and PVC tubing is suitable, but other materials may be used provided that they are compatible with the gas stream. Natural rubber is not recommended due to its tendency to perish. Silicone rubber tubing is not suitable because it readily absorbs and releases CO₂.

Since the gas flows through the instrument, it is essential that particulate contamination be removed from the gas stream. A filter which is capable of removing particles above 1 µm in size should be fitted upstream of the sensor. It is good practice to use a hydrophobic filter (which prevents the passage of liquid water) such as a porous PTFE membrane. Suitable filters are available from Edinburgh Instruments Ltd.

NOTE

Never operate the sensor without a filter. If the sensor is used without a filter, it will function initially but the optics will gradually become contaminated leading to drift in the readings and premature failure of the sensor.

The sensor is capable of operating with up to 100 %RH without ill effect provided that the conditions are non-condensing. If there is any possibility that condensing conditions might occur, the sensor should be protected by a water trap.

If an outlet pipe is connected to the sensor, care should be taken to ensure this does not create a back-pressure in the cell which would lead to erroneous readings (see Section 4.2). The outlet should be free venting via tubing, which is neither too narrow nor too long. It is not advisable to connect the outlet to other sensors or components, which might restrict the flow.

3.3 Electrical connection for GasCheck

The sensor head requires only a +15 V supply (connected to both the source board and the detector board) and provides a 0 to 1 V output, offset from the 0 V rail by 5 V (the +5 V rail is also provided as a reference output voltage)

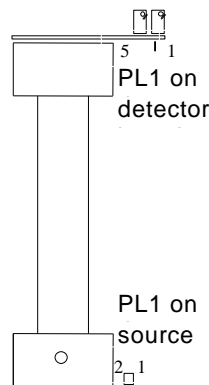

Figure 3.4 Location of the PL1 connectors

Source PCB, PL1	Detector PCB, PL1
pin 1: +15 V	pin 1: +15 V
pin 2: ground	pin 2: ground
	pin 3: 0 to 1 V output
	pin 4: +5 V offset

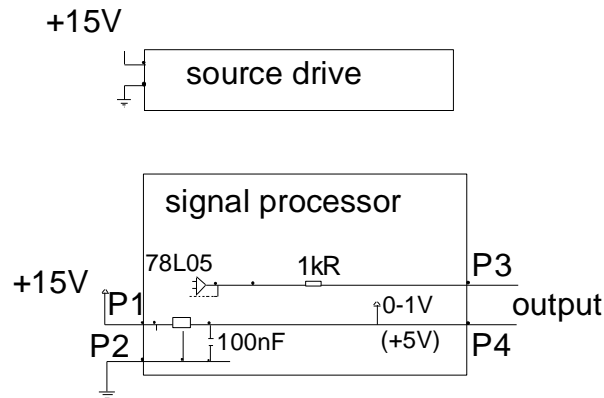

Figure 3.5 Equivalent circuit for GasCheck sensor

There is a 1kΩ resistor in series with the output. This is included to protect the output from damage in the event of it being shorted by the supply rails. The output may be connected to external high impedance circuits (such as non-inverting, op-amp based amplifiers) or low impedance circuits (such as inverting, op-amp based amplifiers). If connected to a low impedance circuit, the output resistance should be included in any gain calculations.

Output resistance = 1 kΩ ± 1% (50 ppm /°C temperature coefficient)

3.4 Electrical Connection - for GasCheck with linearisation board

Electrical connection is normally made at terminal block TB1 on the sensor. The nominal 24V DC supply should be connected between the terminals marked **0V** and **+24V**. The analogue output (current or voltage) is available at the terminals marked + and -.

The - terminal is connected to the 0V terminal thereby referencing the analogue output to the negative power rail.

Alternatively, connections may be made via the 9 way D-type connector PL1 that carries additional signals used during factory testing. The connections for PL1 are:

Pin Number	Function
1	+24V Power Input
2	+Analogue Output
3	AC signal from sensor head
4	+5V rail
5	+15V rail
6	0V Power Input
7	- Analogue Output
8	DC signal from sensor head
9	0 to 2V linear output

3.5 Power supply requirements for GasCheck

The sensor should be connected to a regulated, clean 15 V power supply. The sensor is insensitive to the actual power supply volts and will achieve specification for **steady** supply volts in the range 14.2 V to 15.8 V.

The load current taken by the sensor is not constant and contains significant components at 8 Hz, 1 kHz and their harmonics. The peak current required during normal operation is 300 mA although the average current (to be used for power dissipation calculations) is only 60 mA. The power supply should be capable of supplying this load whilst maintaining a clean regulated output. The inrush current at power-up is 1.2A and the power supply should be capable of supplying this although the supply voltage need not be maintained at 15 V during this time.

A standard 7815 series regulator (not 78L15 version) with a 100 nF output de-coupling capacitor and a 470 nF input de-coupling capacitor is recommended for use with the sensor.

3.6 Power Supply Requirements - for GasCheck with linearisation board

The sensor is designed to operate from a nominal 24V DC supply. The power supply should maintain the voltage between 18V and 30V DC for all load conditions (see below) and all mains voltages.

The power input contains a high frequency filter, but is recommended that a regulated clean power supply be used.

The load current taken by the sensor is not constant and contains significant components at 8Hz, 1kHz and their harmonics. The peak current required during normal operation is 330mA although the average current (to be used for power dissipation calculations is only 100mA). The inrush current at power-up is 1.2A, the power supply should be capable of supplying this although the supply voltage need not be maintained during this time.

3.7 Electrical Connections for the GasCheck with self-referencing

The GasCheck with self-referencing requires a regulated 15V DC supply which must be connected to the terminals labeled 15V (+ve) and 0V (-ve) on PL1.(PL1-1 and PL1-2)

Two outputs are provided:-

1. A 0 to 1V output between the terminals +sig and -sig on PL1. (PL1-3 and PL1-4) This output is non-linearly proportional to gas concentration (refer to appendices at the back of this manual).
2. A calibration error warning output between the terminals marked K (+ve) and A (-ve) on PL1, (PL1-5 and P1-6) suitable for driving a small LED.

4. USING THE OUTPUT

4.1 A Linearisation of the GasCheck

The absorption of infrared energy by a gas is non-linear and therefore the output from the sensor is also non-linear.

The output volts as a function of gas concentration for the various ranges are given in Appendices 1- 3. This may be used to set a trigger or alarm level corresponding to a particular gas concentration.

The output may be linearised using a segmented linearisation technique in which the linearisation curve is approximated to a series of straight lines. This may be achieved, with negligible errors, using the data given in Appendices 1 - 3. Note that the transmitter must always be separately calibrated at zero and span despite this linearisation.

4.1 B Output options for the GasCheck with linearisation

The sensor is supplied configured for a 4-20mA current output with a fault state being indicated by 0mA. Alternative current/voltage outputs are available by changing links on the board and fitting a resistor (voltage outputs only).

To change the output from 4-20mA to 0-20mA, the link on LK1 should be removed and fitted to LK2.

To disable the function, which forces the output to 0mA in the event of the failure of the sensor head, remove LK3.

To provide a voltage output, the current output should be configured as a 0-20mA output (see above) and appropriate resistors should be fitted to positions R36/R37 on the PCB. The output is generated by passing the output current through the parallel combination of R36 and R37. Table 1 gives typical resistance combinations for voltage outputs.

Required Voltage Output	Resistor Values (R36 and R37)
0 - 1V	fit 2 x 100Ω
0 - 3V	fit 2 x 300Ω
0 - 5V	fit 2 x 500Ω
0 - 10V	fit 2 x 1kΩ

TABLE 1

If you require a voltage output that is different to the ones listed in TABLE 1, then you can calculate the required resistor values using Ohm's Law.

$$R = \frac{V}{I}$$

i.e. for 0-10 V output

select 0-20 mA

$$R = \frac{V}{I} = \frac{10}{20 \times 10^{-3}} = 500 \Omega \quad \frac{R_{36}R_{37}}{R_{36} + R_{37}} = 500\Omega$$

$$R_{36} = R_{37} = 1k\Omega$$

500Ω resistance is obtained by fitting 1K resistors to R₃₆ and R₃₇. The maximum available output voltage is limited to 12 volts approximately.

4.2 Temperature and Pressure correction

Because gases are compressible, there are various ways of expressing the gas concentration: volume percent, partial pressure, density, mole density. Infrared instruments operate by measuring the amount of infrared energy absorbed by a sample of the gas and therefore fundamentally measure mole density (the number of molecules in the path of the beam). Most users calibrate their equipment against gases supplied in cylinders and therefore consider the output to be an indication of volume concentration.

The mole density of the gas released from the cylinder depends not only on the gas mixture in the cylinder but also on the ambient pressure and temperature. This means that the output volts from a sensor connected to the same cylinder will vary from day to day depending on the ambient conditions.

The sensor has built in compensation for temperature variation. Pressure correction can be calculated from the ideal gas law, but there is also an increase in absorption per molecule with pressure due to line broadening effects. The sum of these two effects is that the True %V/V is related to the displayed value from the GasCheck by the following relationship.

$$\text{True \% V/V} = \text{Indicated Value} \times \left\{ \frac{P_0}{1.5 \times P - 0.5 \times P_0} \right\}$$

where P = ambient pressure(mBar)

$$P_0 = 1013.25 \text{ (mBar)}$$

For example: if a GasCheck 3000ppm sensor output is 0.978 V, then the linearisation data (Appendix1) states that the reading is 2852ppm. If the ambient pressure is 980 mbar then the true reading can be derived:

$$\text{corrected \% V/V} = 2852\text{ppm} \times \frac{1013.25}{(1.5 \times 980 - 0.5 \times 1013.25)} = 3000\text{ppm}$$

NOTE

All units are factory set to the corrected gas concentration on the day of the manufacture. For maximum accuracy all on-site calibrations should also use pressure and temperature correction.

5. SERVICE AND MAINTENANCE

A full after sales calibration and service facility is provided by Edinburgh Instruments. Service parts and equipment are also available.

5.1 Calibration

Edinburgh Instruments products are inherently stable and will maintain their calibration over extended periods with minimal maintenance. We recommend that the calibration of the GasCheck is checked at least once a year. Any adjustments should be small.

ZERO (nitrogen) and SPAN calibration gases must be applied to the sensor in order to check its calibration. To supply gas from a pressurized bottle a pressure regulator, a needle valve, a gas flow meter and an inlet pipe are needed. When supplying gas the following conditions should be maintained:

- the CO₂ concentration of the SPAN gas should be between 80 and 105 % of the full scale
- the tolerance of the CO₂ volume concentration of the gas bottle should be 2% or better
- the output pressure from the regulator should only slightly exceed the ambient pressure

CAUTION

Never connect cylinders or other pressure sources directly to the sensor as the high pressure in the cylinder may damage the sensor unit.

Gas may be safely connected to the instrument by providing excess flow and venting off the excess gas through an open T-piece with a 1 m pipe connected to it. The procedure for checking/adjusting the calibration is as follows:

1. Any adjustments are made using the ZERO and SPAN adjust potentiometers on the detector printed board (the printed board on the sensor head, see Figure 4.1).

Note: on the linearised version the offset and gain potentiometers VR1 and VR2 on the main PCB are for adjusting out electrical tolerances and should not be used.

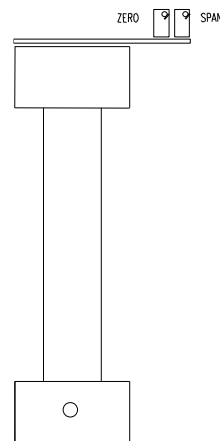

Fig. 4.1 Location of the **ZERO** and **SPAN** adjustment potentiometers

2. The sensor should be **powered for at least 30 minutes** before checking its calibration.
3. Detach both pipes from the sensor head and attach first the **ZERO** gas source to one of the ports. Adjust the needle valve to provide approx. 0.5 l/min to the instrument and allow the instrument to settle (for at least 1 minute) before checking its reading (the instrument reading may kick when opening the gas line). If the reading is outside the required specification, adjust the **ZERO** potentiometer on the detector printed circuit board.
4. Repeat step 3 above with **SPAN** gas. Adjustment is achieved using the **SPAN** potentiometer on the detector printed circuit board. For maximum accuracy, the bottle concentration should be corrected for pressure (see next page).

NOTE

For the diffusion version of the GasCheck with self-referencing, in step 4 remove the rubber cup from the calibration port and then attach zero gas. Remember to refit the rubber cap to the calibration port at the end of the procedure.

Always make adjustments with the **ZERO** gas first and then with the **SPAN** gas.

Gas may also be safely connected to an instrument by transferring it from a cylinder or a gas mixer using gas balloons. Separate balloon assemblies must be used for zero and span gas and different balloons should be used for different span gas mixtures.

NOTE

Balloons should be used only for calibration checking but not for accurate calibration.

When using balloons, take the gas balloon, release the clip valve and expel any air by squeezing it, then close the clip valve. To purge the balloon attach the balloon assembly to the gas cylinder, open the clip valve and allow the gas to flow into the balloon so that the diameter of the balloon increases somewhat. Stop the gas flow and empty the balloon by squeezing it to expel the gas. Close the clip valve.

Again, attach the balloon assembly to the gas cylinder, open the clip valve and fill to a diameter of approximately 20 cm. Then stop the gas flow and close the clip valve. Connect the balloon to the calibration port and after allowing a settling time check the calibration. Check that the balloon is still inflated at the end of the procedure.

Because the sensor fundamentally measures mole density and not volume percent (see Chapter 3.2), it is advisable to calculate the targeted instrument reading corresponding to the span gas concentration with the ambient pressure taken into account in order to achieve maximum accuracy from the GasCheck sensor.

The targeted concentration reading is given by equation

$$TCR = \frac{BC \times (1.5 \times P - 0.5P_0)}{P_0} \quad (2)$$

where:

TCR	=	targeted concentration reading (ppm or %),
BC	=	bottle concentration (ppm or %),
P	=	ambient pressure (hPa or mbar)
P ₀	=	1013.25 (mbar)

EXAMPLE:

If the GasCheck 3000 is to be calibrated with 3000 ppm gas on a day when the ambient pressure is 980 hPa, using equation (2) the output reading should be adjusted to read an equivalent to

$$TCR = \frac{3000 \text{ ppm} \times (1.5 \times 980 - 0.5 \times 1013.25)}{1013.25} = 2852 \text{ ppm.}$$

From the linearisation curve, this corresponds to 0.978V.

NOTE

All units are factory set to the corrected gas concentration on the day of manufacture. For maximum accuracy all field calibrations should also use pressure and temperature correction.

5.2 Trouble shooting

If your GasCheck sensor fails to function, we suggest you return it to Edinburgh Instruments for repair.

However, if you wish to attempt a repair yourself, in the following list you will find a few symptoms and likely causes to assist your efforts. Before proceeding, please familiarize yourself with the operating principle (Section 2).

NOTE

Service should only be carried out by personnel experienced in the repair of electronic equipment including surface mount technology; suitable professional tools and equipment will be required.

Symptom	what to do
output stuck at overrange	<ul style="list-style-type: none"> •check that reading could be valid; apply zero gas and re-check output •check that source is flashing; flashing light should be visible through source PCB, if not see below •check that S.O.T.(Select On Test) resistor R5 on detector PCB is fitted properly •check PL1-5 on detector PCB for the presence of a rectified sinewave
source not flashing	<ul style="list-style-type: none"> •check power to source PCB •depower sensor and measure source resistance which should be $\approx 7 \Omega$; if reads open circuit, the source has failed: see Section 5.3 •check oscillator running on source PCB; IC22 pin 9 should have CMOS level at crystal frequency
sensor unresponsive to gas	<ul style="list-style-type: none"> •check that gas is reaching sensor •check that S.O.T. resistor R13 on detector PCB is properly fitted
no output	<ul style="list-style-type: none"> •check power to detector PCB •check 5 V and 12 V power rails on the detector PCB

5.3 Source replacement

The infrared source comprises a tungsten filament lamp. The lamp has been specially designed and treated to give stable output in the infrared over an extended period. In case of a source failure, the GasCheck must be returned to Edinburgh Instruments for repair.

6. TECHNICAL DATA

Measurement range:

GasCheck 3000	0 to 3000 ppm CO ₂
GasCheck 3%	0 to 3% CO ₂
GasCheck 10%	0 to 10% CO ₂

Accuracy:

	at zero	at full scale
GasCheck 3000	±30 ppm CO ₂	±90 ppm CO ₂
GasCheck 3%	±0.03 % CO ₂	±0.09 % CO ₂
GasCheck 10%	±0.1 % CO ₂	±0.3 % CO ₂

(±1% of full scale ± 2% of reading)

Repeatability:

	at zero	at full scale
GasCheck 3000	<±15 ppm CO ₂	<±45 ppm CO ₂
GasCheck 3%	<±0.015 % CO ₂	<±0.045 % CO ₂
GasCheck 10%	<±0.05 % CO ₂	<±0.15 % CO ₂

(at zero <±0.5% of full scale, at full scale <±1.5% of full scale)

Stability (over one year):

GasCheck 3000	<±150 ppm CO ₂ /year
GasCheck 3%	<±0.15 % CO ₂ /year
GasCheck 10%	<±0.5 % CO ₂ /year

(< ±5% of full scale)

General

Response time (T ₉₀):	20 s with pump
(10 to 90 % response)	50 s with diffusion aspiration

Zero drift

with time:	<±2% of full scale / year
with temperature:	<±0.1% of full scale / °C

Sensing technique:	single beam NDIR
--------------------	------------------

Analogue outputs:	non-linear 0 to 1 V
-------------------	---------------------

Power supply:	15 VDC (14.25 to 15.75 V)
Typical power consumption:	0.9 W

Warm-up time (at normal ambient conditions):

operational	3 min
full specification	5 to 15 min depending on installation

Operating temperature:	0 to +45 °C
------------------------	-------------

Storage temperature: -20 to +60 °C

Operating humidity range: 0 to 100 %RH (non-condensing)

Electromagnetic compatibility

The GasCheck sensors have successfully passed the following tests:

RF field emission	EN 55022
RF field susceptibility	IEC 1000-4-3

Although the sensors have passed these tests, they cannot be provided with the CE label due to the fact that they are OEM products, which are designed to be integrated by the user.

The product described in this manual is subject to continuous development and while every effort has been taken to make sure that the information given is correct, Edinburgh Instruments Limited cannot accept any liability for errors and omissions or their consequences.

7. WARRANTY

Edinburgh Instruments Ltd. guarantees the equipment against defective materials or workmanship for a period of one year from the date of the delivery. In no event shall the Company be liable for any consequential loss or damage arising from failure of the equipment under warranty.

At the end of the one-year period, all claims upon and all liability from failure of the equipment shall be absolutely at an end.

No warranty is made or implied as to the suitability of any equipment for the Purchaser's intended use beyond such performance specifications.

The Purchaser warrants

That they will carefully examine and list all parts of the equipment supplied by Edinburgh Instruments Ltd. and notify Edinburgh Instruments Ltd. in writing of any shortage, defect or failure to comply with the contract, which is or ought to be apparent upon such examination and test, within 48 hours of the equipment being delivered to or collected by the Purchaser.

That the equipment will be operated in accordance with the instructions and advice detailed in the appropriate operating instruction manual, or any other instructions which may be provided by Edinburgh Instruments Ltd. Edinburgh Instruments Ltd. shall not be held responsible for any defect arising from the Purchaser's failure to comply with these recommendations and instructions or from damage arising from negligence or exposure to adverse environmental conditions.

The warranty is effective only if:-

The equipment has been paid for in accordance with the normal payment terms and conditions.

Any defects in the equipment supplied are notified immediately by the Purchaser to Edinburgh Instruments Ltd.

The equipment is returned to Edinburgh Instruments Ltd. at its Livingston premises, transportation and insurance prepaid, and undamaged by the failure to provide sufficient packaging.

The warranty covers:-

Engineer costs to inspect and repair.

Materials or components, that require to be replaced.

Return carriage costs to the Purchaser.

The timing of the inspection and repair of the equipment will be determined entirely at the discretion of Edinburgh Instruments Ltd.

8. DOCUMENT HISTORY CHANGE

VERSION	ECN	DATE
1.0	ORIGINAL	24/02/2000
2.0	6276	20/09/2000
2.1	6310	14/02/2001
2.2	6585	01/11/2004
2.3	6675	20/02/2006
2.4	7017	04/04/2011

APPENDIX 1

Gascheck Linearisation Curve 0.3%

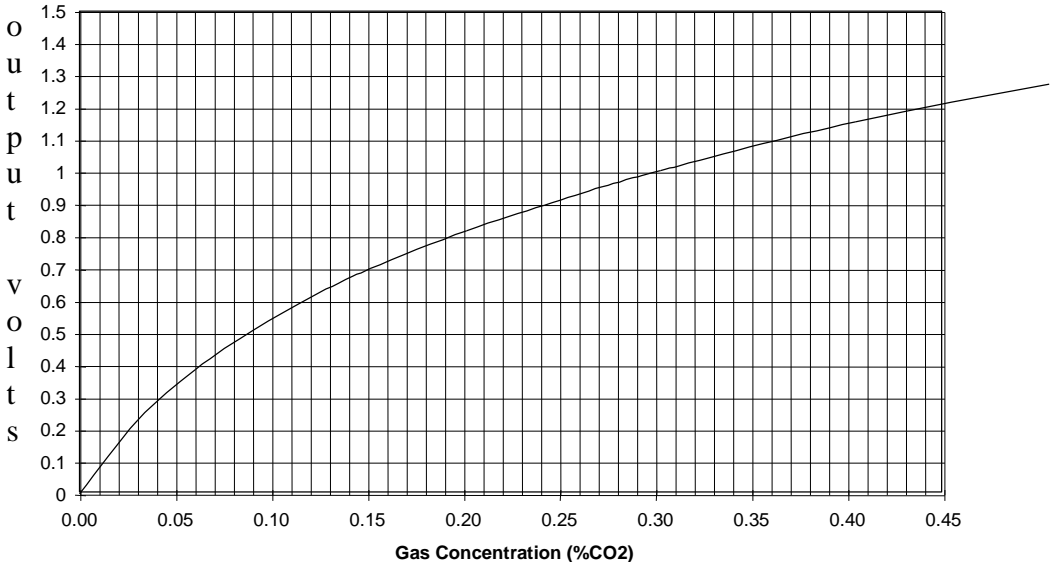

APPENDIX 2

Gascheck Linearisation Curve 3%

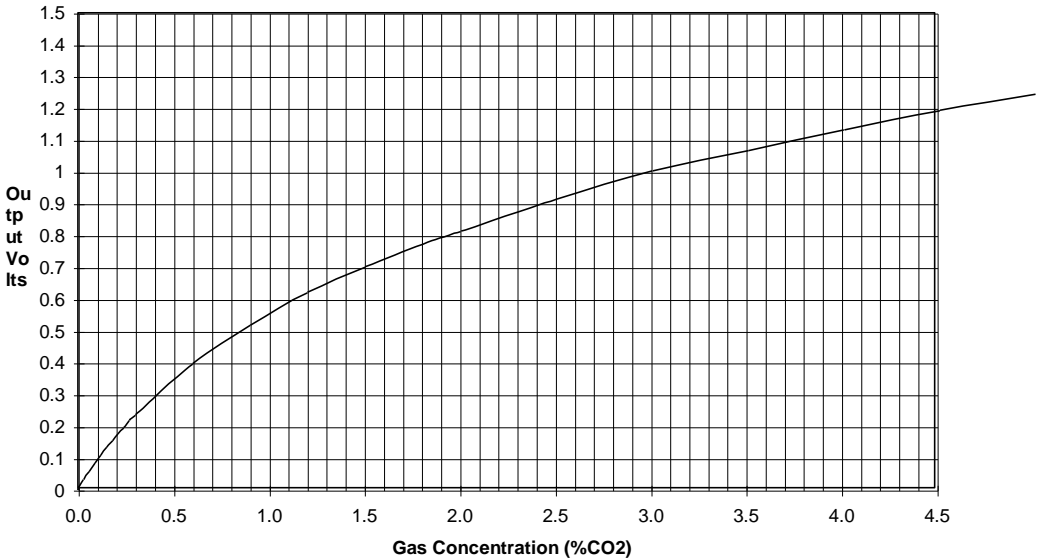

APPENDIX 3

GasCheck Linearisation Curve 10%

