

IRgaskiT

OPERATING MANUAL

Edinburgh Sensors

Division of Edinburgh Instruments Ltd.

2 Bain Square, Kirkton Campus, Livingston, EH54 7DQ, Scotland, UK

Tel: + 44 (0)1506 425300, Fax: + 44 (0)1506 425320

© Edinburgh Instruments Limited, 2011

All rights reserved. No part of this document may be reproduced or transmitted in any form or by any means without prior permission of the copyright holder.

The product described in this manual is subject to continuous development and, while every effort has been taken to ensure that the information given is correct, Edinburgh Instruments Limited cannot accept any liabilities for errors and omissions or their consequences.

CONTENTS

SECTION	PAGE
1.0 INTRODUCTION	3
2.0 SENSOR HEAD OPTIONS	4
3.0 CONNECTING THE SENSOR MODULES.....	6
4.0 FUNCTIONALITY OF THE BOARD	9
5.0 ELECTRICAL CONNECTIONS	10
6.0 ANALOGUE OUTPUTS.....	14
7.0 TECHNICAL DATA.....	15
8.0 SERVICE AND MAINTENANCE	16
9.0 WARRANTY	16
10.0 CALIBRATION.....	17
11.0 PRESSURE EFFECTS.....	19
12.0 SERIAL COMMANDS	20
13.0 DOCUMENT HISTORY	22

1.0 INTRODUCTION

Please take a few minutes to read the manual to ensure ease of installation with other equipment and to maximize the use of the facilities available.

The IRgaskiT infrared gas sensor is designed for integration with a wide range of systems that require accurate and reliable measurement of carbon dioxide or methane gas concentrations.

IRgaskiT provides a temperature compensated bench with single button calibration and optional simultaneous voltage and current outputs. Digital communications are easy to utilize and IRgaskiT PC data logging software is also available.

The sensor head is based on a patented technique that provides true, dual wavelength infrared sensing with no moving parts. The result is a low drift, high accuracy sensor with a fast response time and low power consumption.

Each module of the IRgaskiT has been designed to allow the user maximum flexibility when choosing a solution that meets their application requirements.

2.0 SENSOR HEAD OPTIONS

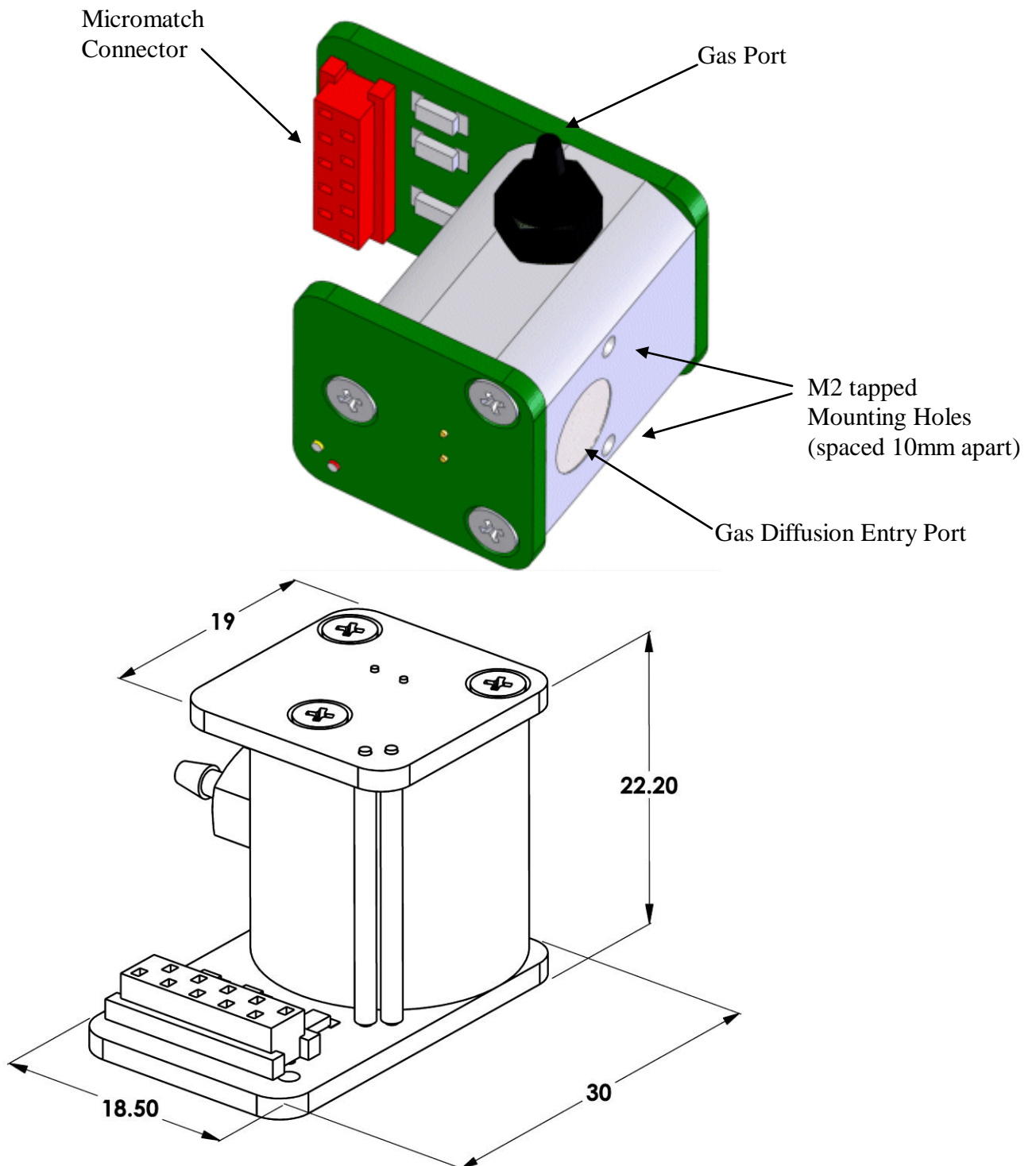

Figure 1 IRgaskiT Sensor Head for 10%, 20% AND 30% CO₂

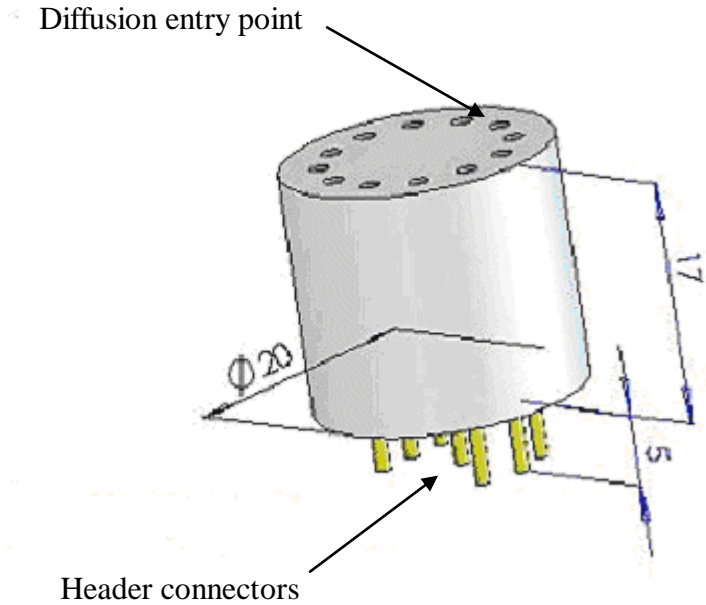

Figure 2 1-5% CO₂ and Hydrocarbon Module

3.0 CONNECTING THE SENSOR MODULES

The supporting electronics for the sensor heads shown in Figure 1 and Figure 2 are modular. There are three circuit boards as shown in Figure 3, which can be connected as shown in Figure 4 or by means of ribbon/flying lead connectors as shown in Figure 5. The processor board is necessary with any configuration option, as this board supplies all the inputs and processes all the output signals from the sensor head. The processor board stores the necessary linearisation and temperature compensation factors and calibration data for its associated sensor head.

The IRceL sensor head plugs into the detector PCB (Detector Board) which then connects to the processor board; the IRgaskiT sensor head is connected directly to the processor board by a flying lead. The detector board is only required for the IRceL, providing mechanical and electrical interfaces to the processor board.

Processor Board	
<u>Input power</u> 5V DC +/-5% power supply at < 200mA	<u>Outputs</u> 2 off 0 – 2V DC
Interface Board	
<u>Input power</u> 7- 13V DC power supply at < 250mA (supply)	<u>Outputs</u> 4-20mA current output (external 0 – 2V DC RS232 Communications

Note: All 3 PCBs can be fixed into position using the fixing holes in the four corners.

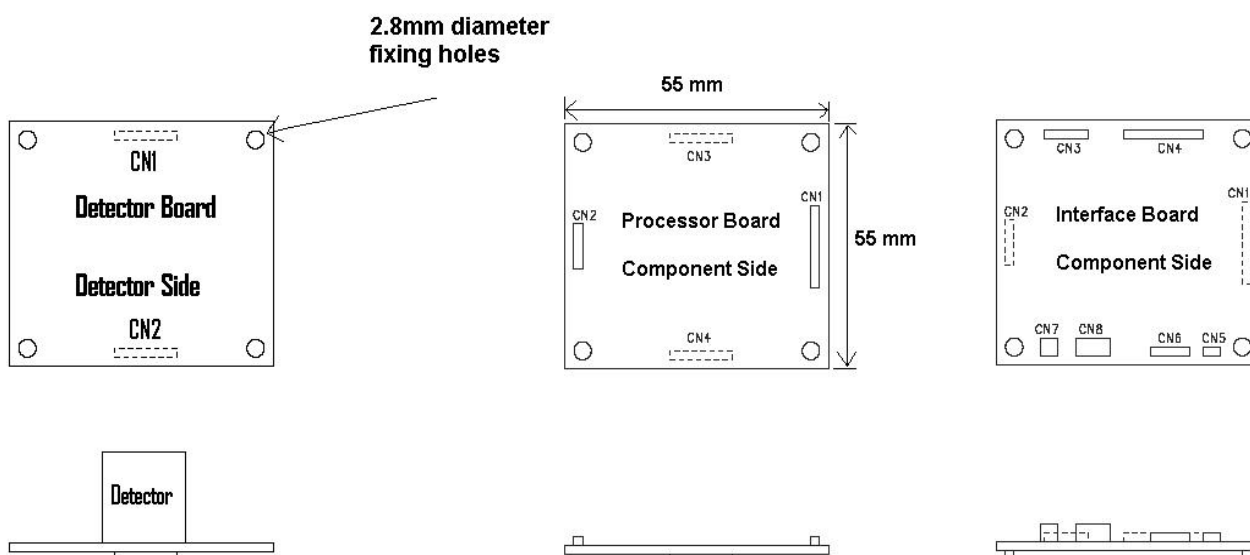

Figure 3 IRgaskiT PCBs

All three boards can plug together as shown below:

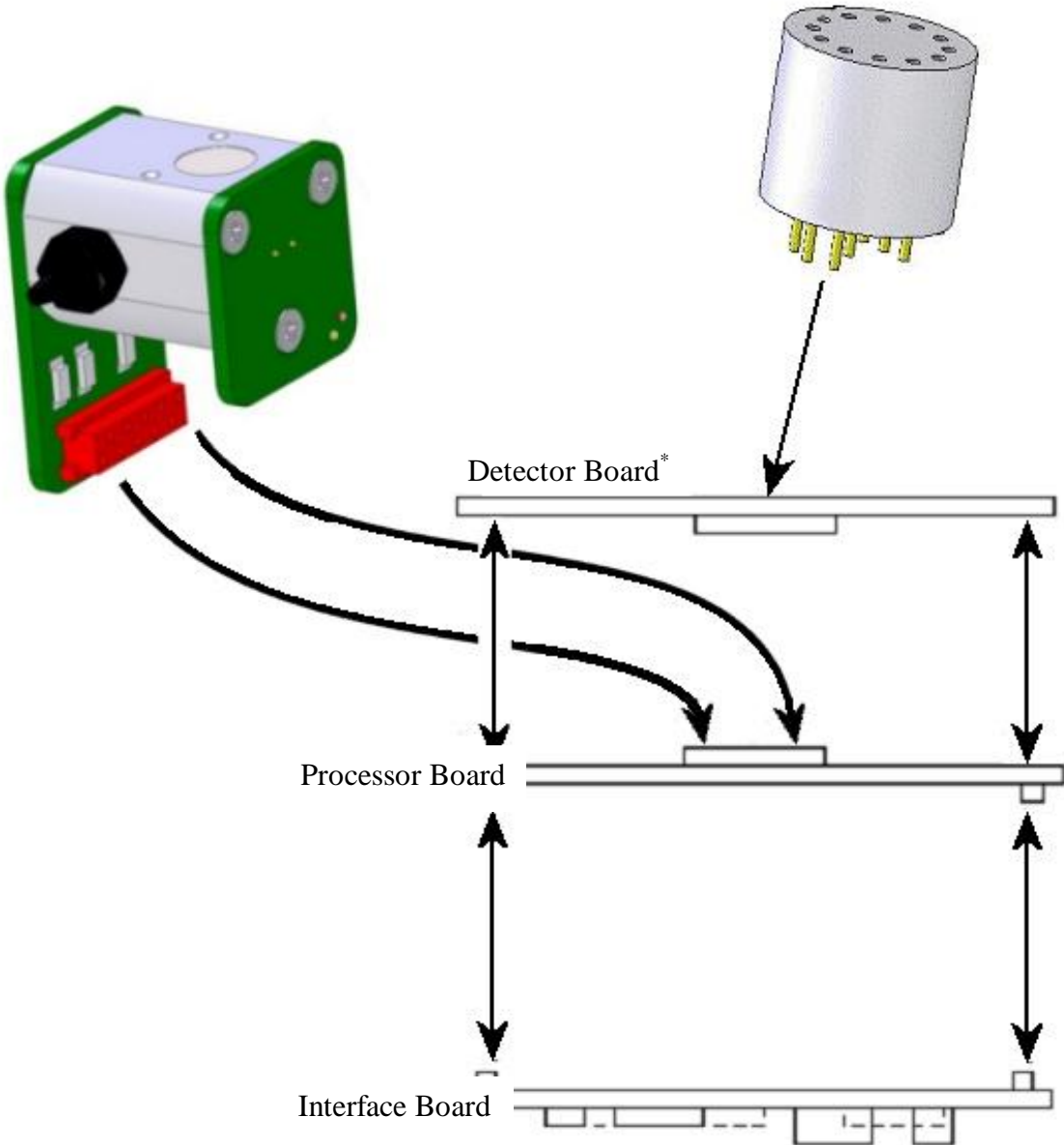

Figure 4 IRceL or IRgaskiT Fitted to PCBs Connected Without Leads

Detector Board* – Removable and replaceable detector is seated on this board

Processor Board – Contains signal and data processing electronics

Interface Board – Support for digital communications and regulated power supply

***This detector board is used only in conjunction with IRceL**

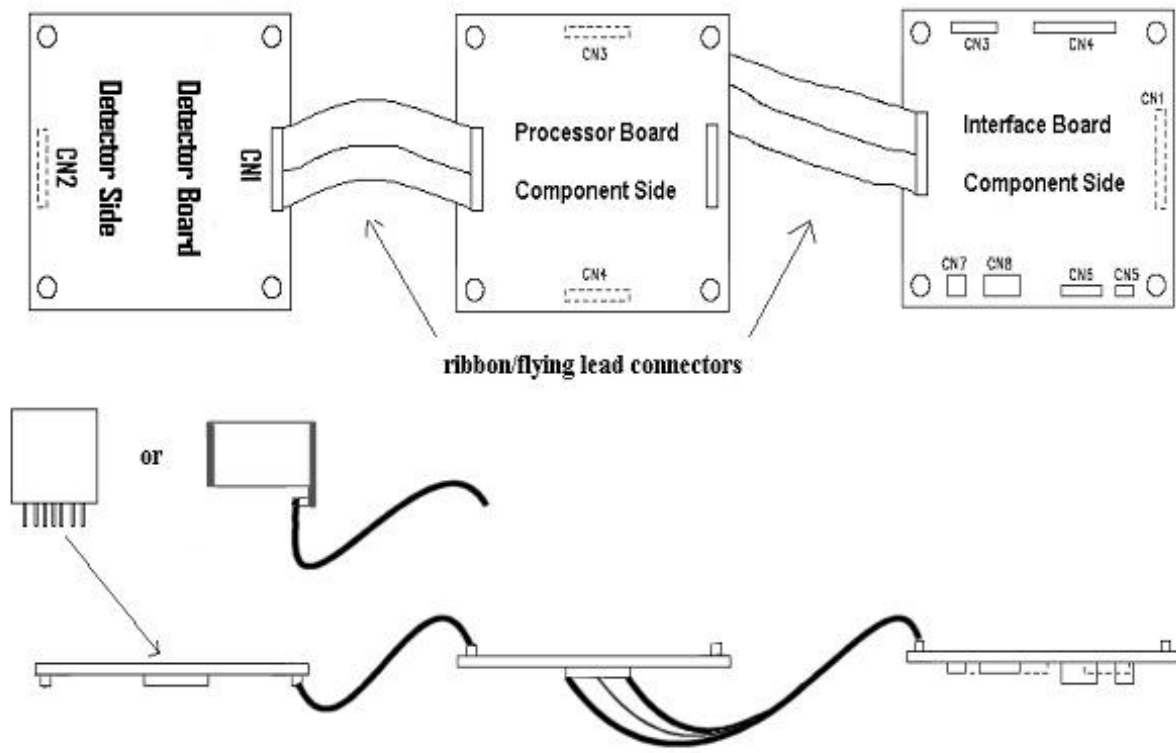

Figure 5 IRgaskiT PCBs Connected With Leads

4.0 FUNCTIONALITY OF THE BOARD

4.1. Interface Board External Connections

CN7 – Power Input (7-13VDC Pin1 +ve, see section 5.0)
 CN8 – Analogue Output (See sections 5.0 and 0)
 CN3 – RS232 Interface

4.2. Processor Board LED's

D1 – (Green) Power on.

D2 – (Yellow) Flashes on/off synchronous with the lamp in normal operation and remains on to indicate the calibration routine is running.

4.3. Interface Board Buttons

ZERO CAL:– Forces a Zero calibration

Apply zero gas and press the button and hold for 5 seconds to start the zero calibration. The yellow LED (D2) on the processor board will remain on until calibration is complete, before returning to the flashing mode which indicates that the board is in normal operation and the zero correction factor has been stored.

SPAN CAL:– Forces a Span calibration

Apply span gas and press the button and hold for 5 seconds to start the span calibration. The yellow LED (D2) on the processor board will remain on until calibration is complete, before it returns to the flashing mode which indicates that the board is in normal operation and the span correction factor has been stored.

For a description of the other board connectors see the tables in section 5.0.

4.4. Block diagram of the sensor:

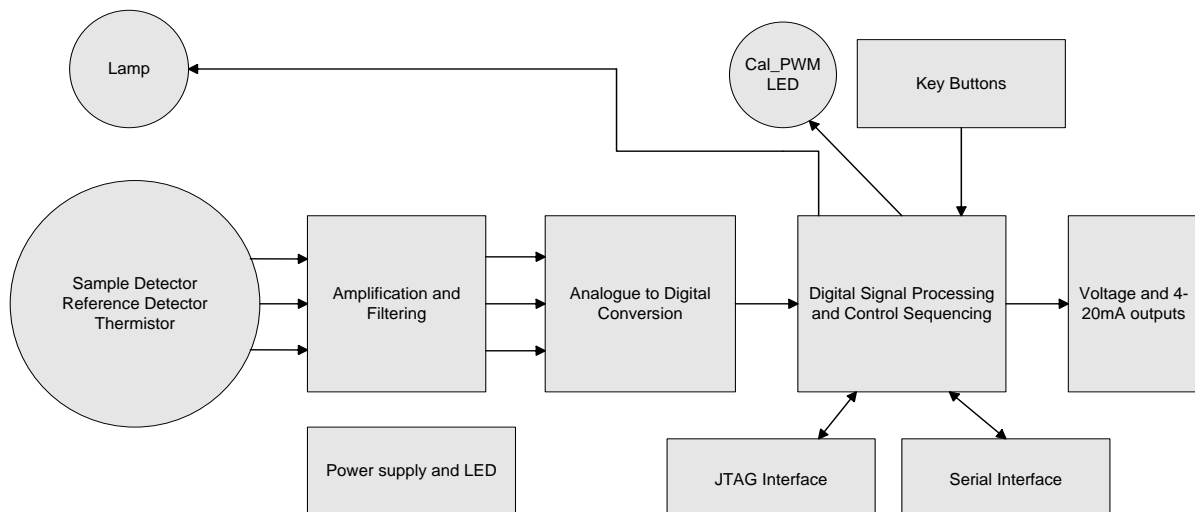

5.0 ELECTRICAL CONNECTIONS

5.1. Processor Board:

Connector	Signal type	Remarks
CN1	Signal I/O	Input and output signals
pin1	analogue output 1	0 to 2V, 0.2mA max, source only, output resistance Ro 100R
pin2	analogue output 2	0 to 2V, 0.2mA max, source only, Ro 100R
pin3	analogue ref	Reference for analogue outputs, Ro 10R
pin4	analogue input	Spare ADC input, biased to mid-point of ADC supply
pin5	analogue input	Spare ADC input, biased to mid-point of ADC supply
pin6	analogue com	Common for analogue inputs
pin7	digital input	Zero calibrate, active low, 10K pull up resistor to +3.3V
pin8	digital input	Reset processor, active low, 10K pull up resistor to +3.3V
pin9	digital input	Interrupt request, active low, 10K pull up resistor to +3.3V
pin10	digital input	Spare input, 10K pull up resistor to +3.3V
pin11	digital input	Spare input, 10K pull up resistor to +3.3V
pin12	digital input	Span calibrate, active low, 10K pull up resistor to +3.3V
pin13	digital input	Spare input, 10K pull up resistor to +3.3V
pin14	digital output	Serial communications Tx, 10K pull up resistor to +3.3V
pin15	digital input	Serial communications Rx, 10K pull up resistor to +3.3V
pin16	digital com	+3.3V digital supply common, Board ground
CN2	Power input	Board and lamp drive circuit supplies
pin1	+5V supply	Lamp drive circuit +5V supply
pin2	+5V supply	Board +5V supply
pin3	+5V supply	Board +5V supply
pin4	Supply com	Board supply common, Board ground
pin5	Supply com	Board supply common, Board ground
pin6	Supply com	Lamp drive circuit supply common
CN3	Detector interface	Detector connections
pin1	Lamp return	Switched lamp return
pin2	Lamp +V	+ve lamp supply
pin3	analogue com	Detector supply common
pin4	detector supply	+ve detector supply
pin5	detector temp	Detector thermistor connection
pin6	analogue com	Detector supply common
pin7	detector sam	Detector sample channel signal
pin8	analogue com	Detector supply common
pin9	detector ref	Detector reference channel signal
pin10	analogue com	Detector supply common

Connector	Signal type	Remarks
CN4	Test	Signal test points
pin1	+3.3V	+3.3V digital supply test point, Ro 10K
pin2	Digital com	Digital supply common/board ground test point, Ro 100R
pin3	+3.15V	+3.15V analogue supply test point, Ro 10K
pin4	Analogue com	Analogue supply common test point, Ro 100R
pin5	Sample	Amplified detector sample signal test point, Ro 10K
pin6	Reference	Amplified detector reference signal test point, Ro 10K
pin7	Detector temp	Detector temperature signal test point, Ro 10K
pin8	Lamp control	Lamp drive mosfet gate signal test point, Ro 10K
CN5	JTAG/OnCE	JTAG/On-Chip Emulator signals
pin1	TCK	Test clock input
pin2	TMS	Test mode select input
pin3	TDI	Test data input
pin4	TDO	Test data output, 10K pull up to 3.3V
pin5	DE	Debug event, 10K pull up to 3.3V
pin6	TRST	Test reset, 10R to digital common

5.2. Interface Board:

Connector	Signal type	Remarks
CN1/CN4	Signal I/O	Input and output signals
pin1	analogue i/p	Voltage amplifier input
pin2	analogue i/p	Voltage to current converter input
pin3	Analogue com i/p	Common input to voltage amplifier and V to I converter
pin4	N/A	Connection between CN1 and CN4 only
pin5	N/A	Connection between CN1 and CN4 only
pin6	N/A	Connection between CN1 and CN4 only
pin7	Passive	Zero calibrate switch contact
pin8	N/A	Connection between CN1 and CN4 only
pin9	N/A	Connection between CN1 and CN4 only
pin10	N/A	Connection between CN1 and CN4 only
pin11	N/A	Connection between CN1 and CN4 only
pin12	Passive	Span calibrate switch contact
pin13	N/A	Connection between CN1 and CN4 only
pin14	digital input	RS232 communication generator circuit Tx input
pin15	digital output	RS232 communication generator circuit Rx output
pin16	Passive	Zero and span switch commons

Connector	Signal type	Remarks
CN2	Power output	Power to drive other boards
Pin1	+5VL	+5V supply, lamp drive circuit supply (processor board)
Pin2	+5V	+5V supply, processor board supply
Pin3	+5V	+5V supply, processor board supply
Pin4	Ground	Supply common, board ground
Pin5	Ground	Supply common, board ground
Pin6	Ground	Supply common, board ground
CN3	RS232 I/F	RS232 communications connector
Pin1	NC	No connection
Pin2	NC	No connection
Pin3	RS232Tx	Data transmit at RS232 levels
Pin4	NC	No connection
Pin5	RS232Rx	Data receive at RS232 levels
Pin6	NC	No connection
Pin7	NC	No connection
Pin8	NC	No connection
Pin9	Ground	Supply common, board ground
Pin10	NC	No connection

Connector	Signal type	Remarks
CN5	Power output	Auxiliary power output connector
Pin1	+5VL	+5V supply, connected to CN2 pin1
Pin2	+5V	+5V supply, connected to CN2 pin2&3
Pin3	Ground	Supply common, board ground
Pin4	Ground	Supply common, board ground
CN6	Auxiliary I/O	Auxiliary I/O connector
Pin1	Passive	Zero calibrate switch contact
Pin2	Passive	Span calibrate switch contact
Pin3	Passive	Zero and span switch commons
Pin4	Ground	Supply common, board ground
Pin5	Voltage output	0 to +4V max output, source only 0.2mA max, Ro 100R
Pin6	Voltage return	Voltage output return, Ri 100R to board ground
Pin7	Current input	4-20mA current control, External supply +ve
Pin8	Current output	4-20mA current control, External supply -ve
CN7	Power input	Power input connector
Pin1	+V supply	7 to 13 V DC supply
Pin2	Supply common	Supply common, board ground
CN8	Signal output	Signal output connector
Pin1	Voltage output	0 to +4V max output, source only 0.2mA max, Ro 100R
Pin2	Voltage return	Voltage output return, Ri 100R to board ground
Pin3	Current input	4-20mA current control, External supply +ve
Pin4	Current output	4-20mA current control, 100R to ground, External supply -ve

5.3. Connector Type and Possible Suppliers:

The range of connectors used on the IRgaskiT is called Micro-MaTch and is manufactured by Tyco Electronics. Mating parts for these connectors are available through a number of distributors. Ready-made ribbon cables with plugs are also available. The Micro-MaTch male-on-wire connector is specifically designed to be disengaged from its counterpart by pulling the cable in the appropriate direction.

For example: the manufacturer's part number for the 16-way male-on-wire plug is 8-0215083-6, and it is available in the UK from RS as part number 341-7423, or from Farnell as part number 149-147.

6.0 ANALOGUE OUTPUTS

6.1. Processor Board

The board has two analogue outputs (CN1 pins 1 and 2) which are both referenced to the analogue reference (CN1 pin 3). The analogue reference is set to approximately 33mV above the board ground.

Analogue output 1: This output is typically scaled 0V to 2V for zero to full-scale gas concentration. See section 5.0 for output specification

Analogue output 2: This output is intended to drive a 4 to 20mA current loop circuit and is typically scaled 0.4V to 2V for zero to full-scale gas concentration. See section 5.0 for output specification.

6.2. Interface Board

Current output:

The 4-20mA current output is configured in a sink arrangement. Connector CN8 pins 3 and 4 should be attached to an external supply and current measurement circuit. The voltage across pins 3 and 4 should be maintained between 10V and 20V. CN8 pin 4 is connected to the board ground via an on board 100R resistor. The current output is normally 4mA to 20mA for zero to full-scale gas concentration. The typical external circuit configuration is shown in Figure 6, below.

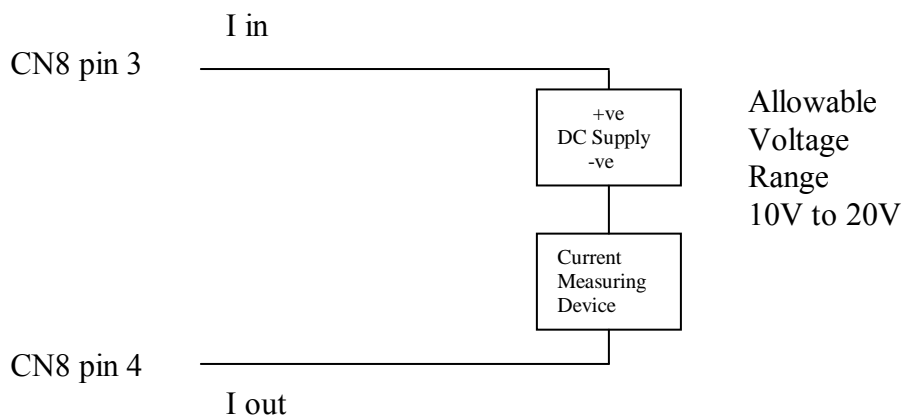

Figure 6, 4-20mA Current Output

Voltage output:

A voltage output is available between CN8 pin 1 (+ve) and pin 2 (return). The maximum output voltage is 4V at a maximum output current of 0.2mA for normal operation. The output is configured as a source only and will not sink current. The scaling is normally set to 0V to 2V for zero to full-scale gas concentration. Pin 2 is connected to the board ground via an on board 100R resistor. See section 5.0 for output specification.

7.0 TECHNICAL DATA

	IRceL	IRgaskiT head
Measuring range CO ₂	0...2% CO ₂	0...10%, 0...20%, 0...30%
Accuracy at 20 °C	± 5 % of range*	± 5 % of range*
Repeatability		
at SPAN	< ± 3% of range	< ± 3% of range
at ZERO	< ± 1% of range	< ± 1% of range
Response time (T ₉₀)	< 60 seconds	< 300 seconds
Long Term Drift month	< +/-0.05% vol. CO ₂ / month	< +/-0.5% vol. CO ₂ /

7.1. Operating conditions

Operating temperature	-20...+50 °C	0...+50 °C
Storage temperature	-20...+70 °C	-20...+70 °C
Humidity range (non-condensing)	5...99 % RH (non-condensing)	5...99 % RH (non-
Sensor protection	diffusion filter	diffusion filter

7.2. General

Analogue outputs	4 to 20 mA, 0 to 2 V	4 to 20 mA, 0 to 2 V
Recommended external load:		
current output	max. 500 Ω	max. 500 Ω
voltage output	min. 20kΩ	min. 20kΩ

7.3. Mechanics

Dimensions(mm)	20.4(diam.) x 16.6(excl. pins)	25 x 14 x 25
Weight	23g	15g

*including linearity and calibration uncertainty

The product described in this manual is subject to continuous development and while every effort has been taken to make sure that the information given is correct, Edinburgh Instruments Limited cannot accept any liability for errors and omissions or their consequences.

8.0 SERVICE AND MAINTENANCE

The IRgaskiT is inherently stable and is supplied fully tested and calibrated. In the unlikely event of failure of the unit, it should be returned to Edinburgh Instruments for test and repair.

9.0 WARRANTY

Edinburgh Instruments Ltd. guarantees the equipment against defective materials or workmanship for a period of one year from the date of the delivery. In no event shall the Company be liable for any consequential loss or damage arising from failure of the equipment under warranty.

At the end of the one-year period, all claims upon and all liability from failure of the equipment shall be absolutely at an end. No warranty is made or implied as to the suitability of any equipment for the Purchaser's intended use beyond such performance specifications.

The Purchaser warrants

That they will carefully examine and list all parts of the equipment supplied by Edinburgh Instruments Ltd. and notify Edinburgh Instruments Ltd. in writing of any shortage, defect or failure to comply with the contract, which is or ought to be apparent upon such examination and test, within 48 hours of the equipment being delivered to or collected by the Purchaser.

That the equipment will be operated in accordance with the instructions and advice detailed in the appropriate operating instruction manual, or any other instructions which may be provided by Edinburgh Instruments Ltd. Edinburgh Instruments Ltd. shall not be held responsible for any defect arising from the Purchaser's failure to comply with these recommendations and instructions or from damage arising from negligence or exposure to adverse environmental conditions.

The warranty is effective only if:-

- The equipment has been paid for in accordance with the normal payment terms.
- Any defects in the equipment supplied are notified immediately by the Purchaser to Edinburgh Instruments Ltd.
- The equipment is returned to Edinburgh Instruments Ltd. at its Livingston premises, transportation and insurance prepaid, and undamaged by the failure to provide sufficient packaging.

The warranty covers:-

- Engineer costs to inspect and repair.
- Materials or components, that require to be replaced.
- Return carriage costs to the Purchaser.

The timing of the inspection and repair of the equipment will be determined entirely at the discretion of Edinburgh Instruments Ltd.

10.0 CALIBRATION

Edinburgh Instruments Ltd products are inherently stable and will maintain their calibration over extended periods with minimal maintenance. We recommend that the calibration is checked every 12 months.

ZERO (nitrogen) and SPAN calibration gases must be applied to the sensor in order to check its calibration. To supply gas from a pressurised bottle, a pressure regulator, a needle valve, a gas flow meter and an inlet pipe are required. When supplying gas, the following conditions should be maintained:-

- ◆ the concentration of the SPAN gas should ideally be 100% of the instrument full scale range, with the balance being air or N₂. If 100% is not available, the IRgaskiT can be calibrated with gas which is within the range 50% to 110% of full scale, but only after setting the available gas variable appropriately, see section 12.0
- ◆ the tolerance (accuracy) of the SPAN gas volume concentration of the gas bottle should be 2% or better.
- ◆ output pressure from the regulator should only slightly exceed the ambient pressure
- ◆ the nominal gas flow should be about one litre per minute into a suitable calibration adapter or where applicable, 0.2 litres per minute directly into the sensor head gas port.

The material of the gas inlet pipe can be nylon, PVC or neoprene; never use silicon rubber as this can affect the gas concentration. The inlet pipe should be no longer than 2 meters.

CAUTION !

Never connect unregulated cylinders or other high-pressure sources to the sensor as the high flow rate from the cylinder may damage the instrument.

10.1. Calibration Procedure

The procedure for checking/adjusting the calibration is as follows:-

1. The instrument should be powered for at least 30 minutes before checking its calibration.

2. Attach the ZERO gas source to the gas inlet of the adapter/sensor head. Adjust the needle valve to provide approximately one litre per minute to a gassing adapter or 0.2 litres per minute directly to the IRgaskiT head and allow it to flush for at least one minute before checking the reading. If the reading is outside the required specification, press and hold the ZERO reset button on the main PCB until the yellow LED on the processor board stops flashing (~5 seconds), or use HyperTerminal serial communications, see Section 12.0.

3. Repeat step 2 above with SPAN gas, if recalibration is required press and hold the SPAN reset button on the main PCB until the yellow LED on the processor board stops flashing (~5 seconds), or use HyperTerminal communications, see Section 12.0.

*Any recalibration necessary will be conducted at the current pressure within the sensor head and so the sensor will read true volume % at the re-calibration pressure if the calibration pressure variable is set to 1013 and the sensor will read true volume % at 1013 mbar if the calibration pressure variable is set to match the ambient pressure prior to re-calibration.

NOTE - Always make adjustments with ZERO gas first and then with SPAN gas.

* see section 11.0 and “environmental variables” sub-section within section 12.0

11.0 PRESSURE EFFECTS

As with all IR gas detectors, the IRgaskiT intrinsically measures the density of the molecules in its absorption cell. As this is a function of the pressure within the cell, it is necessary to correct the indicated concentration for changes in atmospheric pressure. The main reasons for changes of pressure within the head are changes in barometric pressure (due to the weather) and changes in the height of the cell above or below sea level.

The calibration pressure variable of the instrument may be set during factory calibration to the pressure at the time of calibration, in which case the true gas concentration in Vol% is indicated when the ambient pressure is 1013mbar. Alternatively, the calibration pressure variable may be set to 1013 in which case the true gas concentration in Vol% will be indicated when the ambient pressure is the same as the pressure at the time of calibration. If required, the calibration pressure variable can be changed using HyperTerminal (see Section 12.0).

12.0 SERIAL COMMANDS

12.1 Digital Communications Settings

IRgaskiT Data Logger Settings:

Bits per second	57600
Data bits	8
Parity	None
Stop bits	1
Flow Control	Software

HyperTerminal settings:

Bits per second	57600
Data bits	8
Parity	None
Stop bits	1
Flow Control	Xon/Xoff

CAUTION !

The user must only apply the commands described in this manual. Avoid sending any other characters to the IRgaskiT as these may have unwanted effects including loss of calibration and loss of function of the gas sensor.

The IRgaskiT sends out digital data which can be viewed by connecting CN3 of the interface board to the serial port of a PC or similar communications device. The information is updated eight times per second. There are three modes of operation available when using digital communications:

Normal Mode: command = Shift N

This is the default operating mode, and displays the two detector channel signals and the calibrated gas reading:

Display (Normal Mode):

Frequency	Sample Channel	Reference Channel	PWM value	Concentration	Time Constant	Temperature
8	11121	9001	55502	0.9	16	33211

Coefficient Mode: command = Shift C

This mode is used for displaying the linearisation coefficients and serial number. (set during factory calibration)

Display (Coefficient Mode):

Coeff A	Coeff B	Coeff C	Coeff D	Serial Number	Zero temperature coeff	Span temperature coeff	Available SPAN (calibration)	Firmware version
-0.0036	1.2603	-2.1196	1.8629	65534 (max)	0.9800	0.4505	1.00	1.23

The available span variable is set with the command ‘q’ followed by the required number (in the range 0.5 to 1.1)

E.g. if you want to calibrate span with gas that is 95% of full scale, set this number to 0.95 with the sequence ‘q0.95’. Now when the span calibration runs, it will set the concentration to 0.95 .

Environmental variable mode: command = Shift E

This mode is used for displaying the environmental variables including the calibration factors. (set during factory calibration)

Display (Environmental Mode):

Zero Cal. Temp	Span Cal Temp	M_corr	C_corr	A_corr	B_corr	Pressure	Zero Gas corr	Span Gas corr
49204	51278	0.6168	0.0046	0.5007	0.1278	1013	0.4907	0.1664

Calibration Commands:

The calibration routines can be initiated via the serial communication link. This has exactly the same effect as the zero and span buttons on the interface board (which may not be present).

z (lowercase) - starts zero calibration routine – sets the Zero Gas correction variable

s (lowercase) - starts span calibration routine – sets the Span Gas correction variable

After a calibration, the Zero Gas corr and Span Gas corr values will be updated, and the new values can be observed in the Environmental mode.

13.0 DOCUMENT HISTORY

Issue	Date	ECN
1.01	Original	6658
1.20	24-08-2006	6729
1.21	14-04-2011	7018